

375

REDUCED PRESSURE PRINCIPLE ASSEMBLY

WILKINS

APPLICATION

Designed for installation on potable water lines to protect against both backsiphonage and backpressure of contaminated water into the potable water supply. The Model 375 provides high hazard protection where a potential health hazard exists. Ideal for use where lead-free* valves are required.

STANDARDS COMPLIANCE

(Unless Otherwise Noted, Sizes 2 1/2" Thru 10")

- Watermark Cert WMKA1379
- ASSE® Listed 1013
- IAPMO® Listed
- CSA® Certified B64.4 (2 1/2" thru 8")
- AWWA Compliant C511, and C550
- FM® Approved
- UL® Classified
- C-UL® Classified
- Approved by the Foundation for Cross Connection Control and Hydraulic Research at the University of Southern California.



MATERIALS

Main valve body	Ductile Iron ASTM A 536
Access covers	Ductile Iron ASTM A 536
Coatings	NSF Approved fusion epoxy finish
Internals	Stainless steel, 300 Series NORYL™
Fasteners	Stainless Steel, 300 Series
Seal rings	EPDM (FDA approved)
O-rings	Buna Nitrile (FDA approved)
Springs	Stainless Steel, 300 Series
Sensing line	Stainless Steel, braided hose



FEATURES

- Sizes:** 2 1/2", 3", 4", 6", 8", 10"
- Maximum working water pressure:** 175 PSI
- Maximum working water temperature:** 140°F
- Hydrostatic test pressure:** 350 PSI
- End connections (Flanged):** BS10 Table E
*Table D (100mm)

RELIEF VALVE DISCHARGE PORT:

- 2 1/2" - 6" - 2.75 sq. in.
- 8" - 10" - 3.69 sq. in.

ATTENTION:

Model 375 (flange body) and Model 375A (grooved body) have different lay lengths.

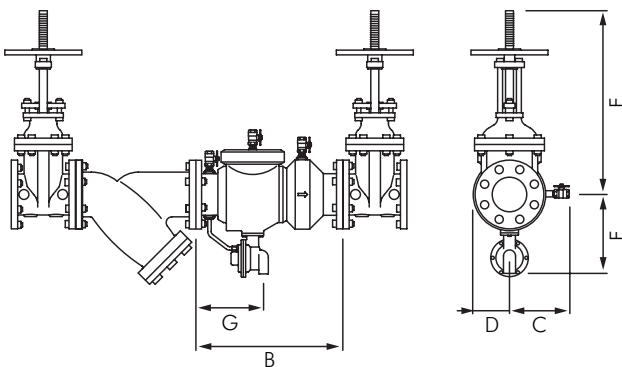

Dimension (approximate)

Model Size mm	B (less gate valves)	F	G	Weight Less Shut-off valve kg
65	403	241	213	27
80	403	241	213	27
100	533	297	235	44
150	673	314	273	79
200	959	391	425	171
250	959	391	425	185

MODEL 375 2 1/2", 3" & 4" (STANDARD & METRIC)

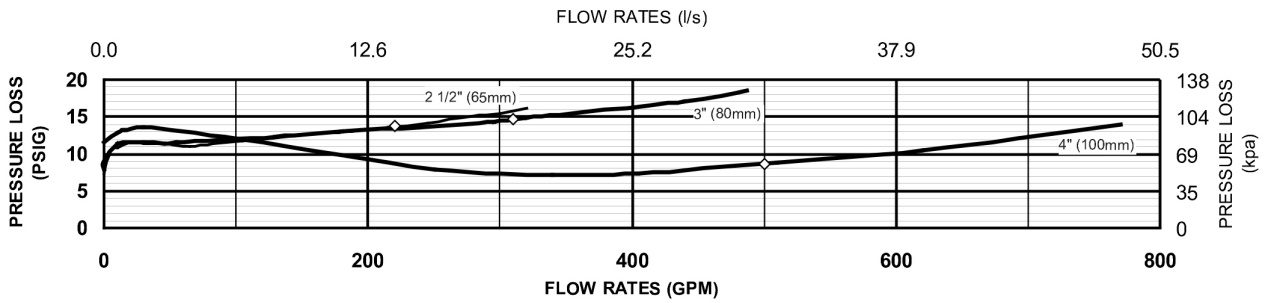

MODEL 375 6", 8" & 10" (STANDARD & METRIC)

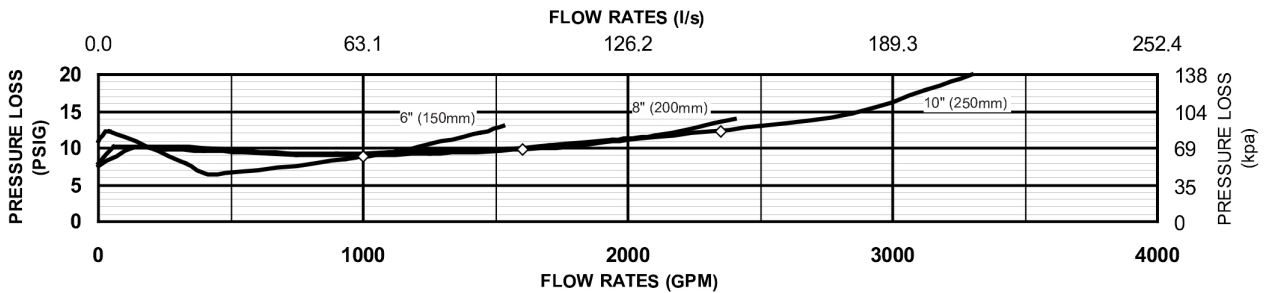

TYPICAL INSTALLATION

Local codes shall govern installation requirements. Unless otherwise specified, the assembly shall be mounted at a minimum of 300mm above adequate drains with sufficient side clearance for testing and maintenance. The installation shall be made so that no part of the unit can be submerged.

Capacity thru Schedule 40 Pipe (GPM)

Pipe size	5 ft/sec	7.5 ft/sec	10 ft/sec	15 ft/sec
2 1/2"	75	112	149	224
3"	115	173	230	346
4"	198	298	397	595
6"	450	675	900	1351
8"	780	1169	1559	2339
10"	1229	1843	2458	3687
12"	1763	2644	3525	5288

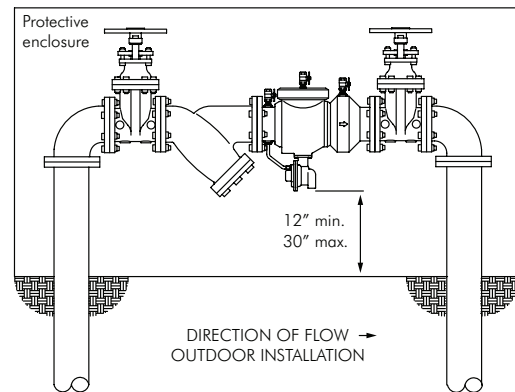
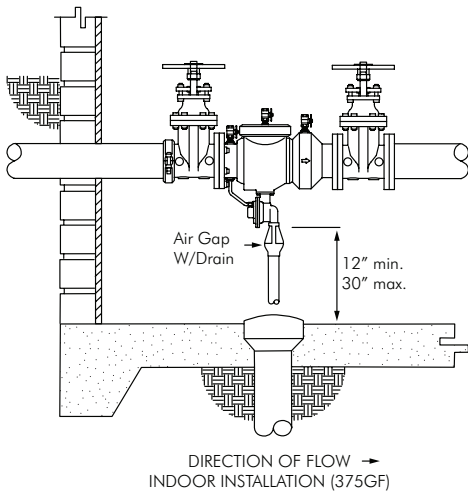

SPECIFICATIONS

The Reduced Pressure Principle Backflow Prevention Assembly shall be certified to NSF/ANSI 61, ASSE® Listed 1013, and supplied with full port gate valves. The main body and access cover shall be epoxy coated ductile iron (ASTM A 536), the seat ring and check valve shall be NORYL™, the stem shall be stainless steel (ASTM A 276) and the seat disc elastomers shall be EPDM. The checks and the relief valve shall be accessible for maintenance without removing the device from the line. The Reduced Pressure Principle Backflow Prevention Assembly shall be a ZURN WILKINS Model 375.



Auckland (Head Office)

20 Carr Rd, Three Kings
Auckland 1041
P: 09 624 1115
F: 09 624 1110
E: sales@macdonaldindustries.co.nz

Wellington

P: 04 569 8033
F: 04 569 8066

Christchurch

P: 03 348 2356
F: 03 348 2376