

AS9014

ASI SURFACE MOUNTED HORIZONTAL BABY CHANGE TABLE

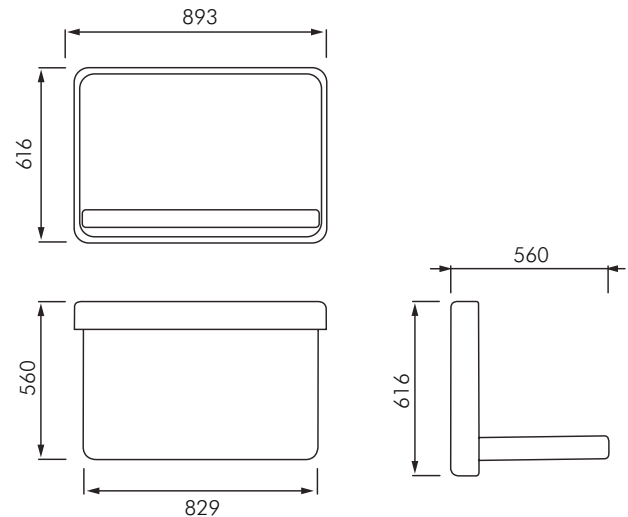

DESCRIPTION

The AS9014 horizontal mounted baby change table is made from durable, easy to clean high density polyethylene which is inherently bacterial resistant.

Entire unit is assembled of completely sealed components to provide easy cleaning and no penetration zones to harbor microbes or bacteria.

Clean design fits virtually all decors and is excellent for cost conscious customers.

Baby change table is light grey in colour.

PRODUCT FEATURES

- Standard with molded-in dual liner dispensers.
- Adjustable two-part vinyl coated child protection safety-strap mounted with concealed fasteners on high walls of cradle.
- Concealed hinges for safety
- Tamper resistant.
- Safety straps with cam-buckle is adjustable with one hand for added security.
- Convenient bag hook.
- Compact, slim profile. Only protrudes 102mm from the wall.
- Pneumatic gas shock mechanism to ensure smooth, safe open and close motions.
- Includes easy to install, step by step instructions plus all mounting hardware.

MODELS

AS9014 - Standard model as shown.



**MACDONALD
INDUSTRIES LIMITED**

Auckland (Head Office)

20 Carr Rd, Three Kings

Auckland 1042

P: 09 624 1115

F: 09 624 1110

E: sales@macdonaldindustries.co.nz

Wellington

P: 04 569 8033

F: 04 569 8066

Christchurch

P: 03 348 2356

F: 03 348 2376

www.macdonaldindustries.co.nz