

BE-SK34

MACDONALD CLEANSEAL SHOWER SYSTEM CORNER EASYSLIDE

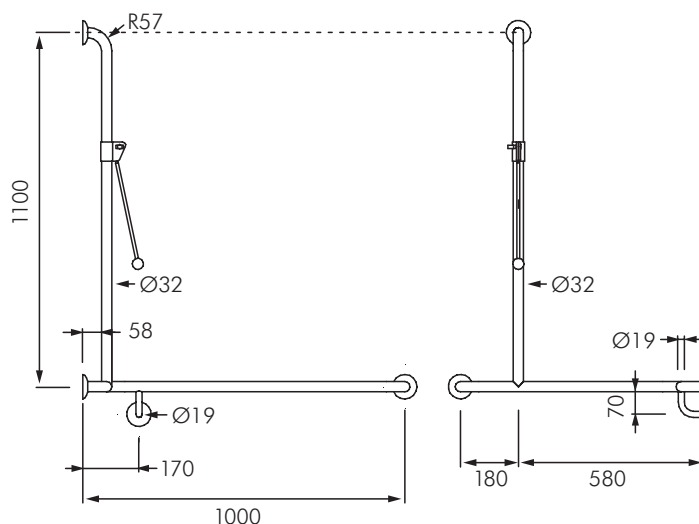

MODEL: BE-SK34L/ESH
 Left handed model shown



DESCRIPTION

The MacDonal BE-SK34 is a corner slide shower system with grab rail, fully welded in grade 304 stainless steel, Ø32mm tubing, with Cleanseal® flange and cover, and Easyslide® handset cradle. The BE-SK34 is suited for use in the shower for hospital, aged care and home assist bathrooms. It's easy to install on most building surfaces and has been designed for maximum strength.

Cleanseal® is an innovative flange and cover system engineered to provide full structural strength, with simple fixing method and hygienically mounted installation. This provides for easily cleaned crevice-free conditions that inhibit bacterial build-up caused by soap scum, body fluid and mould spores.

Easyslide® is a unique handset cradle designed to provide smooth shower positioning and with an encapsulated bush is self cleaning, and keyed to prevent unwanted axial rotation. Optional extended slide handle (ESH) available for seated users.

PRODUCT ADVANTAGES

- Anti-rotation keyed vertical rail.
- Adjustable slide tension on handle cradle.

- Self cleaning slide rail with no obstruction.
- Optional extended slide handle (ESH) for seat users.
- Low maintenance.
- Heavy duty large 75mm flange for extra stability and strength.
- Silicone seals for wall connections.
- Chrome plated hand shower kit includes wall connector elbow, 1500mm hose, and 9L/min shower head.
- Dimensions: Ø32mm, 1100 x 760 x 1000mm.

MODELS

- BE-SK34L** - Left hand shower system - 3 star WELS rating.
- BE-SK34L/ESH** - Left handed shower system with extended slide handle (as shown) - 3 star WELS rating.
- BE-SK34R** - Right hand shower system - 3 star WELS rating.
- BE-SK34R/ESH** - Right hand shower system with extended slide handle - 3 star WELS rating.

