

## Model 100-SSE Special Needs Extended Length Changing Station Installation Instructions



Thank you for purchasing a quality MacDonald's product. Our goal is 100% consumer satisfaction! If, for any reason you are not satisfied or if you have questions regarding your product or installation, please contact our customer service team at our Auckland office on 09 624 1115.

### **WARNING**

- Failure to follow these warnings and the installation instructions could result in serious injury or death.
- Read all instructions before installing the extended length changing station. Keep these instructions. DO NOT discard.

# ASSEMBLY INSTRUCTIONS

ADULT INSTALLATION REQUIRED.

## TOOLS REQUIRED:

- Level (A)
- Measuring tape (B)
- Power drill (C)

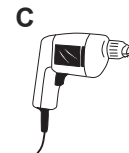
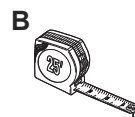

- READ ALL INSTRUCTIONS BEFORE ASSEMBLY OF EXTENDED LENGTH CHANGING STATION.
- Unpack carton and identify all parts.

## ⚠ WARNING

- This changer has six (6) recess mounting holes.
- The diaper changing station is no stronger than the anchors or walls to which they are attached and, therefore, **MUST** be firmly secured in order to support the weight they are intended to support. It is recommended that this unit be installed in a recessed fashion. If surface mounting, contact an architect, building contractor, or Professional Engineer for proper installation and hardware. Contact an architect or building contractor if any questions.
- Child should never be left unattended.
- Avoid serious injury from falling or sliding out. Always use restraint system.
- Adding excessive weight such as parcels, packages, or accessories to the unit or to the bag hooks that exceed the total weight limit of 400 pounds (181.8 kg) may cause the unit to be unstable or may cause a hazardous unstable condition to exist.

## PARTS LIST

Parts Description	Quantity
Door / Wall Plate	1

**IMPORTANT:** Due to widely varied wall material, anchoring to be determined by architect or engineer.



Door / wall plate to be mounted on outside of restroom door.

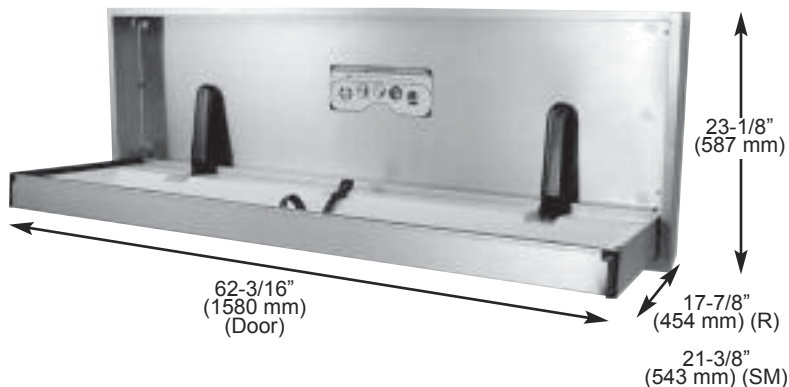

### OPERATION:

Rotate base downward. Place infant on top of the changing surface. Use restraint system as described below. After child has been changed, remove restraint system and rotate base back up against the wall.

### USE OF RESTRAINT SYSTEM:

Place child so restraint strap is located at abdomen. Rotate top of buckle upward and insert strap in buckle. Pull strap through buckle until snug against infant. Rotate top of buckle downward to lock the strap into place. Slide red locking tab over top of buckle (**Fig. a**). Reverse steps to loosen strap.

### MAINTENANCE AND CLEANING:

Check all hardware and components monthly or as required to ensure hardware is tight and there are no missing or damaged components. Take unit out of service if any component is missing or damaged and contact customer service to order replacement parts. Do not substitute parts. For replacement parts, contact customer service at our Auckland office on 09 624 1115.

Clean by using a damp cloth with mild soap or mild multi-purpose cleaner. Do not use and strong chemical cleaners or cleaning agents that may be hazardous to children.

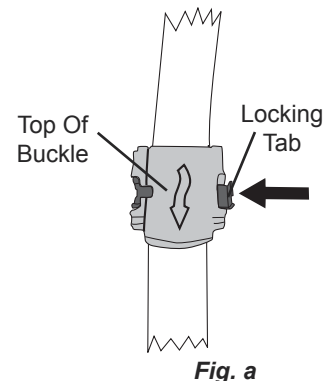

## INSTALLATION - RECESSED

**NOTE:** If installing a surface-mount changing station, see "Installation - Surface-Mount" section.

### Recommended Blocking:

Wood double stud blocking is necessary. Contact an architect and building official to make sure the blocking is adequate and complies with building codes (**Fig. b**).

For **A. D. A.** compliance, top of lower double stud **MUST** be 27" (68.5 cm) from the floor.

1. Slide changer into blocking area and mark mounting hole location on blocking studs.

**HINT:** This may require 2 additional people to help hold changer in position while you are marking the locations.

2. Shim changer for a snug fit.

3. Align holes in changer with marked holes and secure using the appropriate fasteners (**Fig. c**).

**NOTE:** It is installers responsibility to provide correct fasteners for other substrates.

4. Ensure all seven (7) fasteners are tight.

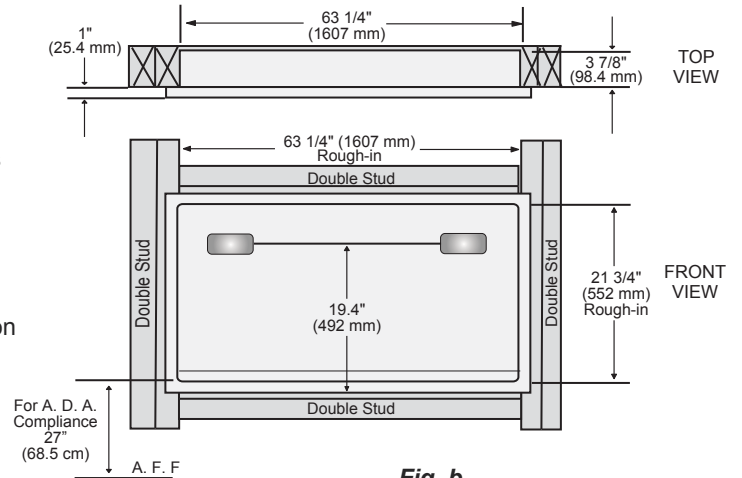

**Fig. b**

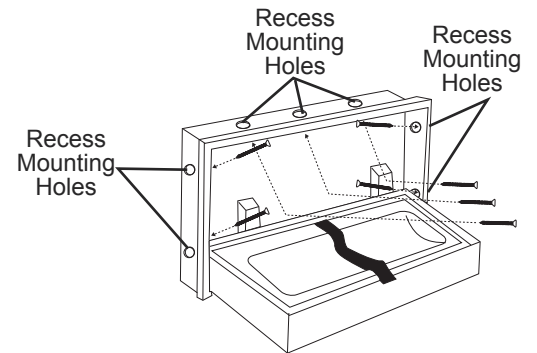

**Fig. c**

## INSTALLATION - SURFACE-MOUNT

### Recommended Blocking:

If the walls do not have studs on center, then additional blocking is necessary (**Fig. d**).

Contact an architect or building contractor to make sure the blocking is adequate and complies with building codes.

For **A. D. A.** compliance, measure up 48 1/2" (123 cm) from the floor and mark the wall. This locates the position for the top left attachment hole.

### NOTE:

- Changer **MUST** be mounted to studs (**Fig. e**).
- This unit incorporates a finishing collar that seats behind the changer's outside flange. Center the collar as the unit is being tightened against the wall (**Fig. f**).

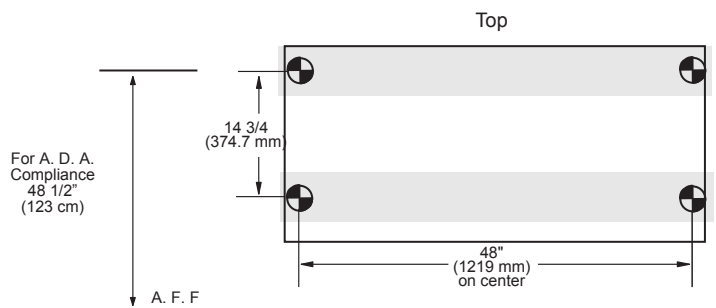

**Fig. d**

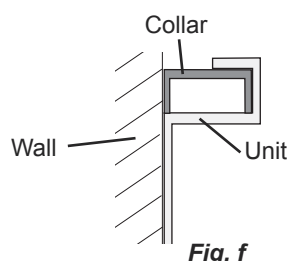

**Fig. f**

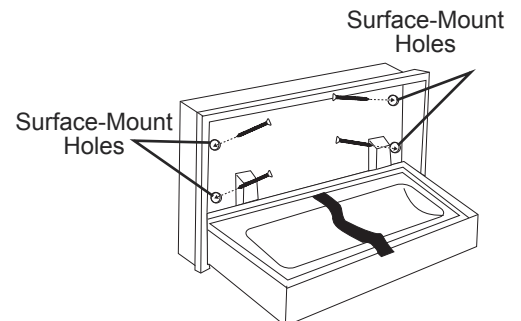

**Fig. e**