

DE2597
BASIN MIXER
WITH RETRACTING HAND-SPRAY

DELABIE

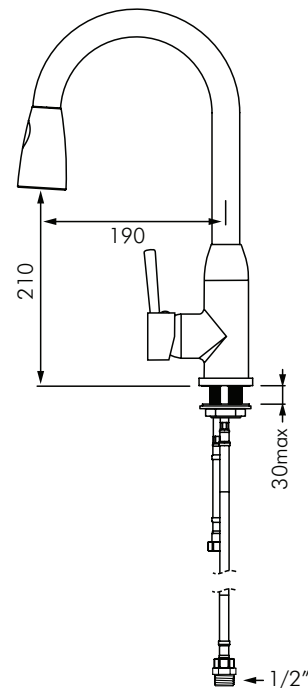

DESCRIPTION

DELABIE DE2597 is a mechanical basin/sink mixer with swivelling swan neck spout H.210 L.190mm and retracting hand spray. Retracting hand spray has 2 jet options; flow straightener or rain effect. Pre-set maximum temperature limiter. Flow rate limited to 9L/min at 300kPa. Operating pressure is 100-500kPa, 300kPa is recommended. Chrome plated solid brass body with slimline control handle, flexible hand spray with integrated non-return valve and reinforced fixing.

Supplied with PEX flexibles, M1/2" connections and reinforced fixing.

INSTALLATION

- Deck mounted through Ø34mm hole.
- Reinforced fixation using 2x stainless steel fixing screws and support ring.
- PEX flexibles and M1/2" connections.
- Ø40mm ceramic cartridge.
- Flow rate pre-set at 9L/min at 300kPa.

MODEL

DE2597 - Standard model 9L/min.