

# DE378MCH

## BINOPTIC MIX ELECTRONIC BASIN MIXER

# DELABIE

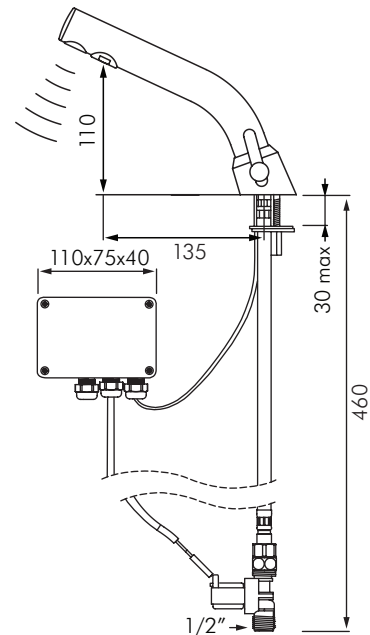

### DESCRIPTION

DELABIE DE378MCH is a deck mounted electronic basin mixer with independent IP65 electronic control unit and shock-proof infrared presence detection sensor at the end of the spout. Available as 230/12V mains supply with transformer or 6V Lithium battery power. Anti-bacterial duty flush operates for ~60 seconds every 24 hours after last use. Side temperature control with adjustable maximum temperature limiter. Flow rate is pre-set at 3L/min at 300kPa, can be adjusted from 1.5 to 6L/min. Operating pressure is 100-500kPa, 300kPa is recommended. Chrome-plated brass body with hygienic scale-resistant flow straightener and reinforced fixing. Spout has a smooth interior and low volume of water (limits bacterial niches).

Supplied with PEX flexibles, solenoid valves, filters and M1/2" stopcocks.

### INSTALLATION

- Deck mounted through Ø34mm hole.
- Reinforced fixation using 2x stainless steel fixing screws and support ring.
- 230V AC power connection to control box.
- 400mm PEX flexibles with filters & solenoids connect to 1/2" water supply.
- Equal Hot & Cold supply pressure (max 15% variation).
- Maximum Hot water temperature 55°C.
- Flow rate pre-set at 3L/min at 300kPa, can be adjusted from 1.5 to 6L/min by using a 2.5mm Allen key directly on the flow straightener.

### MODELS

- DE378MCH** - Standard model 3L/min - 6 star WELS rating.
- DE478MCH** - Same as DE378MCH but battery powered.
- DE378MCHLH** - Same as DE378MCH but with long handle side temperature control.