

DE443436 & DE443536

TEMPOMATIC 4

ELECTRONIC BASIN TAP

DELABIE

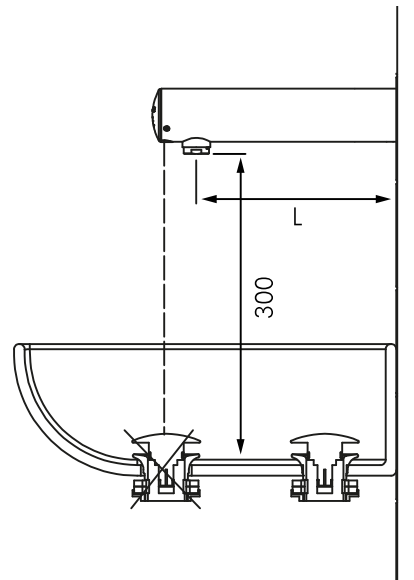

DESCRIPTION

Delabie wall-mounted electronic basin tap. Battery-operated with integrated 6V Lithium batteries. Reduced-stagnation solenoid valve and electronic unit integrated into the body of the tap.

Flow rate pre-set at 3 lpm at 3 bar, can be adjusted from 1.5 - 6 lpm. Scale-resistant flow straightener. Duty flush (~60 seconds every 24 hours after last use). Active infrared presence detection, sensor at the end of the spout optimises detection.

Stainless steel body L.130mm or L.190mm. Wall-mounted, screws directly into 1/2" wingback supplying pre-mixed or cold water. Anti-blocking security.

Suitable for people with reduced mobility.

10-year warranty.

INSTALLATION

- Screws directly into 1/2" wingback
- Water supply should either cold or premixed to $\sim 40^{\circ}\text{C}$
- Ideal for retrofit application
- Ensure sensor position does not conflict with basin waste in order to prevent self activation (refer installation instructions)

MODELS

DE443436 - integrated batteries, L. 130mm - 6 star WELS

DE443536 - integrated batteries, L. 190mm - 6 star WELS

