

## DE5612

### DECK MOUNTED SINGLE HOLE MIXER WITH EXTENSION COLUMN - 100L/MIN

# DELABIE

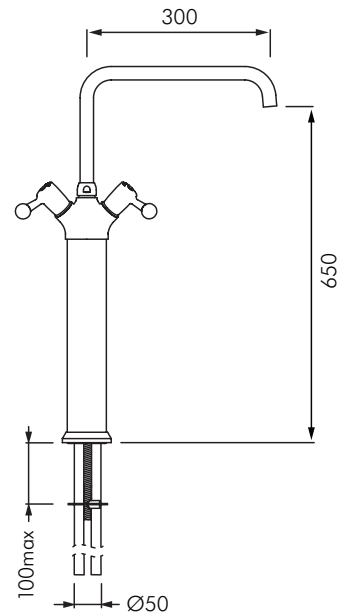

#### DESCRIPTION

DELABIE DE5610 is a deck mounted mixer for commercial kitchens with extension column and swivelling tubular spout. Rapid fill flow rate 100L/min at 300kPa. Chrome plated brass body and spout, shock resistant ball levers for withstanding intensive use. Spout H.560mm L.300mm with smooth interior for reduced bacterial development and star shaped flow straightener. Operating pressure 100-500kPa, 300 kPa recommended. Reinforced fixing through Ø50mm hole with Ø14x16mm copper pipe water inlets.

#### INSTALLATION

- Deck mounted through Ø50mm hole.
- Swivel spout Ø22mm, H.560mm L.300mm.
- Flow rate 100L/min at 300kPa.
- Operating pressure 100-500kPa, 300kPa recommended.
- Ø14x16mm copper pipe water supply connections.
- Reinforced fixing.

#### MODELS

DE5612 - Standard model 100L/min.



**MACDONALD  
INDUSTRIES LIMITED**

#### Auckland (Head Office)

20 Carr Rd, Three Kings

Auckland 1041

P: 09 624 1115

F: 09 624 1110

E: [sales@macdonaldindustries.co.nz](mailto:sales@macdonaldindustries.co.nz)

#### Wellington

P: 04 569 8033

F: 04 569 8066

#### Christchurch

P: 03 348 2356

F: 03 348 2376

[www.macdonaldindustries.co.nz](http://www.macdonaldindustries.co.nz)