

# DE5632

## PRE-RINSE MIXER WITH BIB TAP

# DELABIE

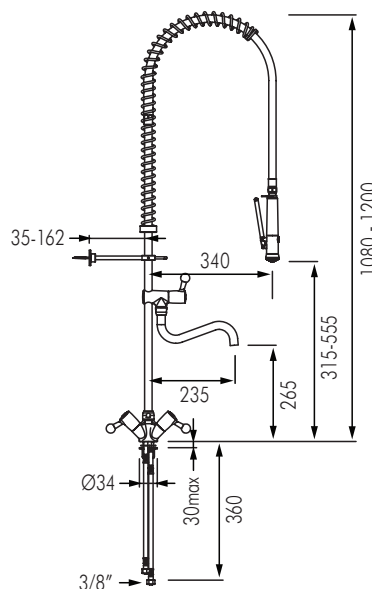

### DESCRIPTION

DELABIE DE5632 is a deck mounted, single hole pre-rinse mixer with twin handle control levers, hand spray and bib tap. The flexible hose is high performance, food grade, reinforced with Hytel, withstanding pressure up to 500kPa and temperatures up to 70°C. Operating pressure 100-500kPa, we recommend 300kPa. Flexible hose has a non-crease, anti-fouling coating as well as a PVC sheath on the stress area and an anti-torsion rotating nut. Hand spray with adjustable jet and 9L/min flow rate at the outlet. Stainless steel spring and spring guide, adjustable wall bracket. Bib tap has swivelling, tubular spout L.200mm. Valve head with reinforced mechanism with ergonomic control lever.

Supplied with M1/2" water connections, non-returns and filters.

### INSTALLATION

- Deck mounted through Ø34mm hole.
- Reinforced fixation using 2x stainless steel fixing screws and support ring.
- PEX flexibles and M1/2" connections.
- Reinforced hose with stainless steel spring guide and anti-torsion rotating nut.
- Adjustable height of the riser column and reinforced fixing by wall bracket.
- Supplied with non-returns and filters.

### MODELS

- DE5632** - Standard model with bib tap and L.0.95m flexible hose.
- DE5630** - Same as DE5632 but without bib-tap.
- DE5632-120** - Same as DE5632 but with 1.20m hose.
- DE5630-120** - Same as DE5630 but with 1.20m hose.