

DE5634

PRE-RINSE SPRAY WITH BIB TAP WALL MOUNTED TWIN HOLE

DELABIE

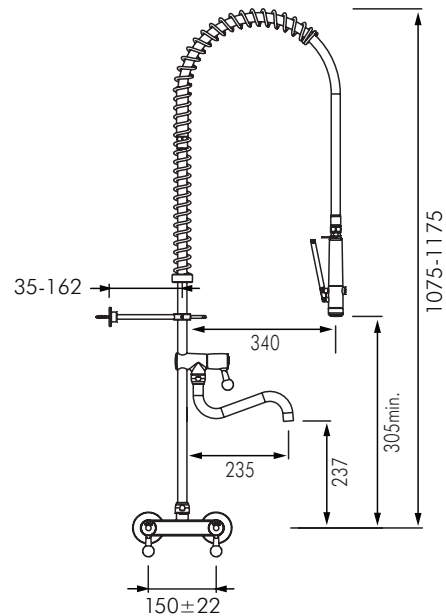

DESCRIPTION

DELABIE DE5634 is a wall mounted, twin hole pre-rinse mixer with twin handle control levers, hand spray and bib tap. The flexible hose is high performance, food grade, reinforced with Hytel, withstanding pressure up to 500kPa and temperatures up to 70°C. Operating pressure 100-500kPa, we recommend 300kPa. Flexible hose has a non-crease, anti-fouling coating as well as a PVC sheath on the stress area and an anti-torsion rotating nut. Hand spray with adjustable jet and 9L/min flow rate at the outlet. Stainless steel spring and spring guide, adjustable wall bracket. Bib tap has swivelling, tubular spout L.200mm. Valve head with reinforced mechanism with ergonomic control lever.

Supplied with M1/2" water connections, non-returns and filters.

INSTALLATION

- Wall mounted through twin Ø22mm holes, 150mm centres.
- Offset inlet connections with M1/2" tails.
- Reinforced hose with stainless steel spring guide and anti-torsion rotating nut.
- Adjustable height of the riser column and reinforced fixing by wall bracket.
- Supplied with non-returns and filters.

MODELS

- DE5634** - Standard model with bib tap and L.O.95m flexible hose.
- DE5636** - Same as DE5634 but without bib-tap.
- DE5634-120** - Same as DE5634 but with 1.20m hose.
- DE5636-120** - Same as DE5636 but with 1.20m hose.