

DE5641T2
DECK MOUNTED TWIN HOLE MIXER
45L/MIN

DELABIE

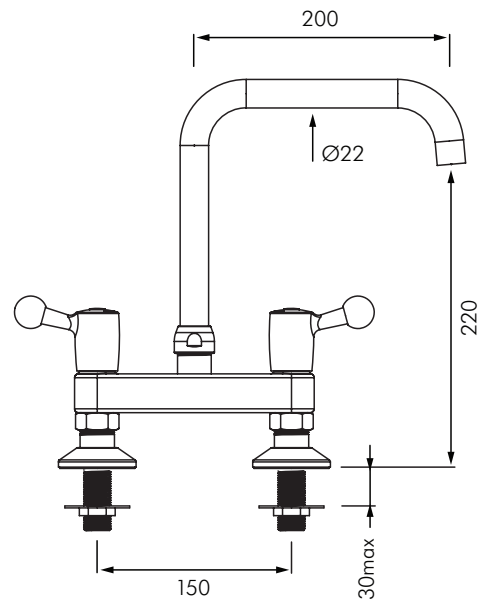

DESCRIPTION

DELABIE DE5641T2 is a deck mounted twin hole mixer for commercial kitchens with swivelling tubular spout. Rapid fill flow rate 45L/min at 300kPa. Chrome plated brass body and spout, shock resistant ball levers for withstanding intensive use. Spout H.235mm L.200mm with smooth interior for reduced bacterial development and star shaped flow straightener. Operating pressure 100-500kPa, 300 kPa recommended. Reinforced fixing with M1/2" water inlets.

INSTALLATION

- Deck mounted through twin Ø28mm holes.
- Swivel spout Ø22mm, H.235mm L.200mm.
- Flow rate 45L/min at 300kPa.
- Operating pressure 100-500kPa, 300kPa recommended.
- M1/2" water supply connections.
- Reinforced fixing.

MODELS

- DE5641T2** - Standard model 45L/min.
- DE5641T3** - Same as DE5641T2 but with H.235mm L.300mm spout.

Auckland (Head Office)

20 Carr Rd, Three Kings
Auckland 1041
P: 09 624 1115
F: 09 624 1110
E: sales@macdonaldindustries.co.nz

Wellington

P: 04 569 8033
F: 04 569 8066

Christchurch

P: 03 348 2356
F: 03 348 2376