

## DE5647T2

### WALL MOUNTED TWIN HOLE MIXER 45L/MIN

# DELABIE

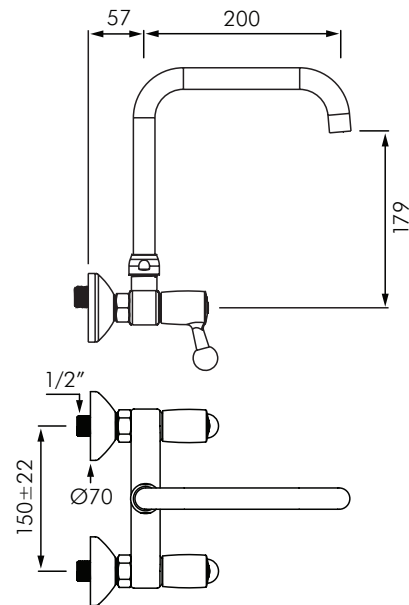

#### DESCRIPTION

DELABIE DE5647T2 is a wall mounted twin hole mixer for commercial kitchens with swivelling tubular over-spout. Rapid fill flow rate 45L/min at 300kPa. Chrome plated brass body and spout, shock resistant ball levers for withstanding intensive use. Spout H.180mm L.200mm with smooth interior for reduced bacterial development and star shaped flow straightener. Also available with H180mm L.300mm spout. Operating pressure 100-500kPa, 300 kPa recommended. M1/2" offset connectors supplied with Ø70mm wall plate.

#### INSTALLATION

- Wall mounted M1/2" connections 150mm centres.
- Swivel spout Ø22mm, H180mm L.200mm.
- Flow rate 45L/min at 300kPa.
- Operating pressure 100-500kPa, 300kPa recommended.
- Reinforced fixing.

#### MODELS

- DE5647T2** - Standard model 45L/min.
- DE5647T3** - Same as DE5647T2 but with H.180mm L.300mm spout.

#### Auckland (Head Office)

20 Carr Rd, Three Kings  
Auckland 1041  
P: 09 624 1115  
F: 09 624 1110  
E: sales@macdonaldindustries.co.nz

#### Wellington

P: 04 569 8033  
F: 04 569 8066

#### Christchurch

P: 03 348 2356  
F: 03 348 2376