

**DEH9716**  
 SECURITHERM  
 THERMOSTATIC BASIN MIXER

**DELABIE**

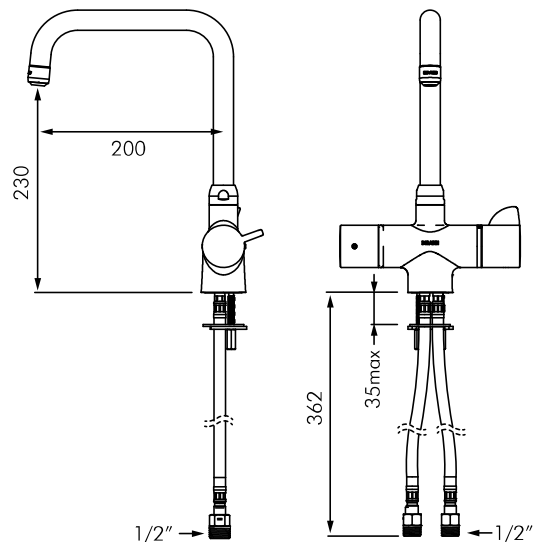

**DESCRIPTION**

DELABIE DEH9716 Securitherm is a deck mounted thermostatic dual control basin mixer with smooth interior. Securitherm thermostatic mixer taps ensures immediate hot water shut off if the cold water supply fails. If the hot water fails the mixer also shuts off. Securitouch thermal insulation prevents burns to the user. 1/4 turn ceramic head for adjusting flow rate. Temperature can be adjusted with two temperature limits; first temperature limit set at 38°C (can be overridden), and second temperature limit 41°C (can be adjusted by installer). Flow rate limited to 5L/min at 300kPa. Operating pressure is 100-500kPa, 300kPa is recommended. Ergo controls. Swivel spout L.200mm H.230mm with smooth interiors. Mixers with smooth interiors have 14x less Biofilm contamination than mixers with standard rough interiors.

Supplied with PEX flexibles, filters, non-returns M1/2" connections and reinforced fixing.

BIOFIL terminal filter available for this tap (see separate BIOFIL literature).

**INSTALLATION**

- Deck mounted through Ø34mm hole.
- Reinforced fixation using 2x stainless steel fixing screws and support ring.
- PEX flexibles, filters, non-returns and M1/2" connections to water supply.
- Flow rate limited to 5L/min at 300kPa.
- Anti-scalding failsafe, Hot water shuts off immediately if cold water fails.
- Temperature limiters; first set to maximum 38°C (can be overridden), second set at 41°C (is adjustable by installer).
- Minimum 15°C difference between HW and MW.
- Maximum 15% pressure differential between HW and CW.
- Thermal shocks are possible with this mixer tap.

**MODELS**

**DEH9716** - Standard model 5L/min - 6 star WELS rating.

**DEH9726** - Same as DEH9716 but with L.150mm H.210mm spout.