

DV-SH07-040 HIGH SECURITY SHOWER HEAD

KWC DVS

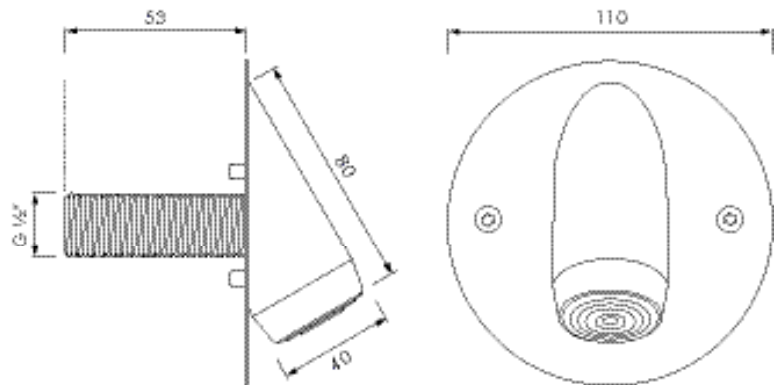

DESCRIPTION

The DV-SH07-040 is a wall mounted 30° angled high security shower head with 4 rings. Substantially reduced ligature risk with a tamper proof security locking plate. This shower head is intended for installations where everything except the showerhead and control are concealed behind a wall or panel.

Brushed 316 stainless steel, with invisible anti-rotating pin. Inlet connection M1/2" BSP thread.

This shower head can be used in conjunction with any of MacDonald shower controllers including Warden electronic, MacDonald Security, or Delabie time delay products.

Ideal for use in applications requiring a high degree of vandalism protection including prisons and mental health facilities, which require water consumption minimisation.

INSTALLATION

- Wall mounted shower head
- M1/2" water supply connection
- Substantially reduced ligature risk
- Minimum water pressure 100kPa
- Flow rate 6L/min at 300kPa

MODELS

DV-SH07-040 - Standard model with 53mm long M1/2" threaded connection

