

# FR-EXOS220

## EXOS HAND DRYER

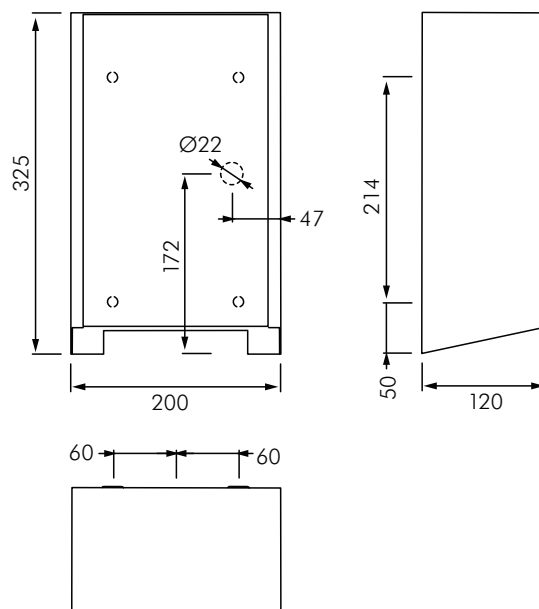

### DESCRIPTION

Franke FR-EXOS220 hand dryer is for wall mounting. Depending on the interior design and the colour scheme, this model is available in three new front panel options; stainless steel with satin finish, white safety glass, and black safety glass. The casing has Franke InoxPlus surface refinement for the reduction of finger marks and better cleaning characteristics (easy to clean). Material thickness 1.2 mm, with contactless opto-electronic sensor for touch-free operation, adjustable hot air temperature, sensor range adjustable from 10 to 25 cm, protection from continuous operation with automatic switch-off after 60 seconds, air speed adjustable, cable and plug not included. Connection voltage: 230 V, 50-60 Hz. Total power: 1000 W. Air volume: 80 m<sup>3</sup>/h. Air velocity: 95-115 m/s. Sound level 96dB. IPX1 protection. Dimensions: 200 x 325 x 120mm (W x H x D).

### MODELS

- FR-EXOS220X** - Franke EXOS hand dryer with satin stainless steel front panel.
- FR-EXOS220W** - Franke EXOS hand dryer with white glass front panel.
- FR-EXOS220B** - Franke EXOS hand dryer with black glass front panel.