

FR-EXOS625

ELECTRONIC SOAP DISPENSER

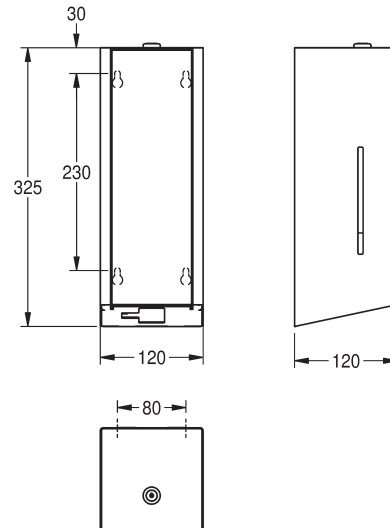

DESCRIPTION

KWC Franke EXOS625 touch free electronic soap dispenser is for wall mounting.

Depending on the interior design and the colour scheme, this model is available in three new front panel options; are stainless steel with satin finish, white safety glass, and black safety glass.

The casing has KWC Franke InoxPlus surface refinement for the reduction of finger marks and better cleaning characteristics (easy to clean). Material thickness is 1.2 mm, inspection window on side, infrared sensor activity for non-touch operation, LED display shows battery status, requires 4 pieces 1.5V AA batteries, suitable for liquid soap and lotions, includes 800 ml refill tank, dispenses 0.6 - 1.1 ml depending on soap, includes mounting materials.

SPECIFICATION

Dimensions: 120 x 325 x 120 mm (W x H x D)

Battery Operated: requires 4 pieces 1.5V AA batteries

Soap Dispenser: includes 800 ml refill tank

Dispenses: 0.6 - 1.1 ml

MODELS

FR-EXOS625X - with satin stainless steel front panel.

FR-EXOS625W - with white glass front panel.

FR-EXOS625B - with black glass front panel.

FR-SO1L - Replacement organic liquid soap, 1 litre bottle.

FR-SO10L - Replacement organic liquid soap, 10 litre canister.



**MACDONALD
INDUSTRIES LIMITED**

Auckland (Head Office)

20 Carr Rd, Three Kings

Auckland 1041

09 624 1115

sales@macdonaldindustries.co.nz

www.macdonaldindustries.co.nz

Christchurch

03 348 2356

christchurch@macdonaldindustries.co.nz

Wellington

04 569 8033