

# INSTALLATION INSTRUCTIONS

# ASI

# AS8026 Mirror

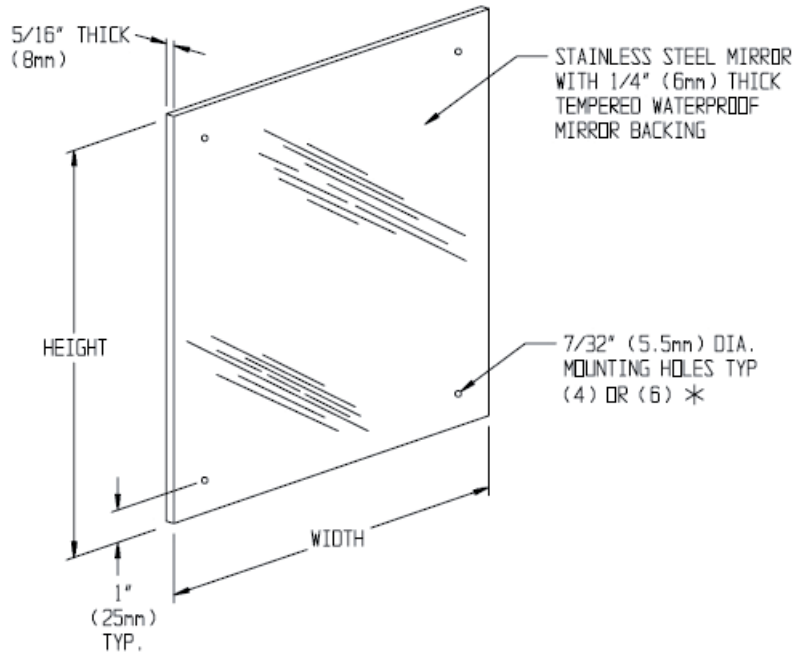

## STANDARD STOCK SIZES

MODEL	WIDTH	HEIGHT	MODEL	WIDTH	HEIGHT
8026-1620	16" (406mm)	20" (508mm)	8026-2430	24" (610mm)	30" (762mm)
8026-1624	16" (406mm)	24" (610mm)	8026-2436 *	24" (610mm)	36" (914mm)
8026-1824	18" (457mm)	24" (610mm)	8026-4824 *	48" (1219mm)	24" (610mm)
8026-1830	18" (457mm)	30" (762mm)			

## MATERIALS

Frameless stainless steel mirror with masonite back 20 gauge is fabricated from Type 304 stainless steel, No.8 mirror finish. Backing is 6mm thick tempered water resistant masonite. Unit has 8mm returns to wall all around. Unit is provided with four 5.5mm dia. mounting holes (fixings by others).

## DESIGNERS NOTE

The reflective quality of a stainless steel mirror is not as true as plate glass. It is not recommended that a mirror of this type be made larger than 48"x24" (1219x610mm) because image quality (distortion) degrades with increased surface size.

## INSTALLATION

Surface mount unit to wall using hardware supplied by installer through four mounting holes provided.



**MACDONALD  
INDUSTRIES LIMITED**

20 Carr Rd  
Three Kings  
Auckland 1042  
Ph 09 624 1115  
Fax 09 6241110  
email:sales@macdonaldindustries.co.nz  
www.macdonaldindustries.co.nz

**Christchurch**  
Ph; 03 348 2356  
Fax: 03 348 2376  
**Wellington:**  
Ph 04 569 8033  
Fax 04 569 8066