

MS-DF-XX

MACDONALD THROUGH WALL DRINKING FOUNTAINS

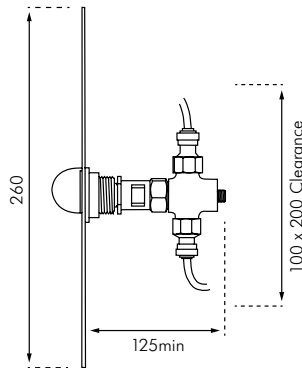

MS-DF180

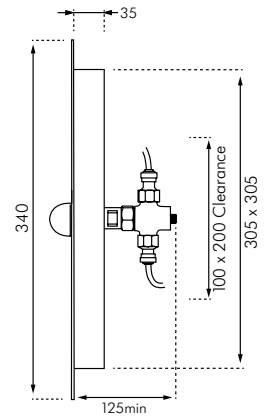

MS-DF340

DESCRIPTION

MS-DF is a vandal resistant wall mounted drinking fountain designed to be installed outside where spilled water can fall to ground.

Pressing the valve button initiates immediate water flow. On release of button water will stop flowing within 3 seconds. Each valve is supplied with a 2L/min flow restrictor to ensure a uniform flow rate.

INSTALLATION

The MS-DF requires a cavity behind the mounting plate to house valve and fittings.

It is available in models allowing:

- Direct fixing to timber or concrete walls (MS-DF180) or,
- Installation using a plate mounting frame with a 340 x 340 panel (MS-DF340)

Valve and bubbler are mounted onto the back of the panel, requiring flexible water supply connections. A short inlet tail of John Guest tubing provides the necessary flexibility. Connections between the valve and bubbler are pre-assembled. Security screws are provided. Please ensure the products are installed onto an appropriate wall/structure to provide a robust installation.

- 1/2" BSP connection
- 100 - 500kPa (recommended 300kPa)

MODELS

MS-DF180 - Standard model as shown with 180 x 260 direct fixed plate.

MS-DF340 - As above but with 340 x 340 panel and 305 x 305 inwall fixing frame.