

MS-Z73DM

MACDONALD SECURITY PRESSURE BALANCING SHOWER MIXER & DIVERTER

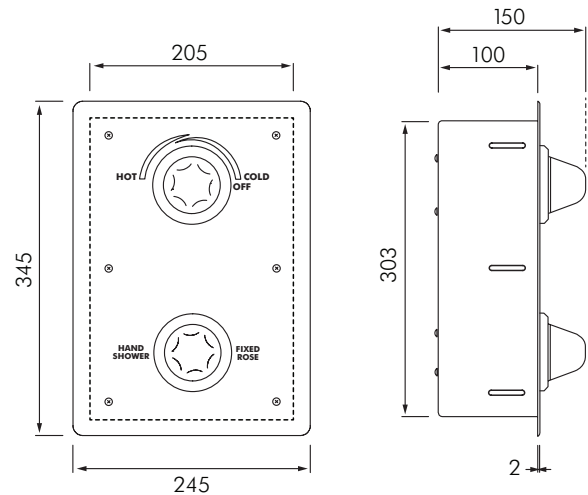

DESCRIPTION

The MacDonald MS-Z73DM is from our range of security fixtures that offer a high level of vandal resistance and have been designed with anti-ligature features to improve the safety and comfort of any secure facility.

The 'lemon squeezer' shaped handle with no flat horizontal surface offers an easy to grip handle while reducing the chance of self-harm.

Mixer is operated by rotating from Off, to Cold through to the Hot position. Pressure balancing cartridge delivers nearly constant water temperature despite pressure fluctuations in either the hot or cold water supply lines giving anti-scald protection to the user. The diverter allows the choice of outlet for when using a shower rose and a detachable hand shower (both supplied separately).

Also available with electronic piezo control providing limits on shower runtime using either Solo single point control or Warden multi point control which also allows remote control by facilities staff. Specify Solo or Warden control separately. Refer to our sales team to assist in selecting suitable model.

The valve inlets and outlet are F1/2". Outlet to shower head must be full diameter pipe to prevent back pressure.

Material for the handles is stainless steel giving a bright smooth finish. Supplied with an installation box to provide additional strength and support for the shower valves and face plate.

INSTALLATION

- Pressure range 100-500kPa, 300kPa is recommended.
- F1/2" connections to water supply.
- Flow rate limited to 9L/min at 300kPa.
- Pressure balancing cartridge, balances pressure fluctuations between hot and cold water supplies.
- Pre-set maximum temperature limiter (is adjustable by installer).
- Maximum 35kPa pressure differential between hot and cold water supplies.
- Stainless steel face plate dimensions: 245 x 345mm.

MODELS

- MS-Z73DM** - MacDonald Security pressure balancing shower mixer and diverter including stainless steel face plate and installation box.