

RA-JU1113 / 1115
JUNIOR WALL FACED TOILET PAN

RAK
CERAMICS



PACK INCLUDES

- RA-JU11100P back to wall childs WC
- Fixing kit ref RA-FS37UK
- RA-JU145300 Urea soft close seat & lid (Model RA-JU1113)
- SA56.049 seat only (Model RA-JU1115)
- Installation Instructions
- Warrantee Form

NOTES

- Inspect all items thoroughly immediately on receipt to ensure it meets your requirements.
- Inspect product for defects prior to installation. MacDonald Industries will not be responsible for any claims related to replacements after a product has been installed.
- Ensure floor on which WC is to be installed is level and of a suitable material for installation of a WC.
- Check water pressure does not exceed 500kPa. Fit pressure reducing valve if necessary.
- Check water inlet / waste outlet positions are correct for the WC supplied according to the measurements in Dia. 1.
- All measurements provided are based on finished wall/floor.
- Installation must only be completed by a registered plumber in accordance with AS/NZS3500 requirements.
- Only fix WC's through floor mounting brackets supplied. **NEVER** attempt to fix through back wall.
- Where floor is sloped bed the WC using a sand and cement mixture or proprietary levelling compound.

INSTALLATION

- Position WC onto pan connector checking that it fits tight to the back wall and floor.
- Mark the position of fixing brackets on the floor and then remove WC. **Do not use fixing holes as a guide for drilling as damage may occur.**
- Drill holes into floor as per Dwg 2 and fix mounting brackets.
- Ensure floor is clean of dirt, dust or impurities.
- Re-fit WC securing it to the mounting brackets using sleeves/screws supplied.
- Ensure WC has fitted correctly to inlet water pipe and waste outlet and check pan for level.
- Fit chrome screw caps supplied.
- Apply a bead of flexible mould resistant silicon around base of pan.

On completion of installation, flush lines of any debris and then connect supply to valves.

If WC is installed in conjunction with a flushing valve, remove internal components of the flush valve according to manufacturers recommendation, then open stop cock to flush debris/air for at least 1 minute. Reassemble flush valve at test flush.

MACDONALD INDUSTRIES LIMITED
INSTALLATION INSTRUCTIONS

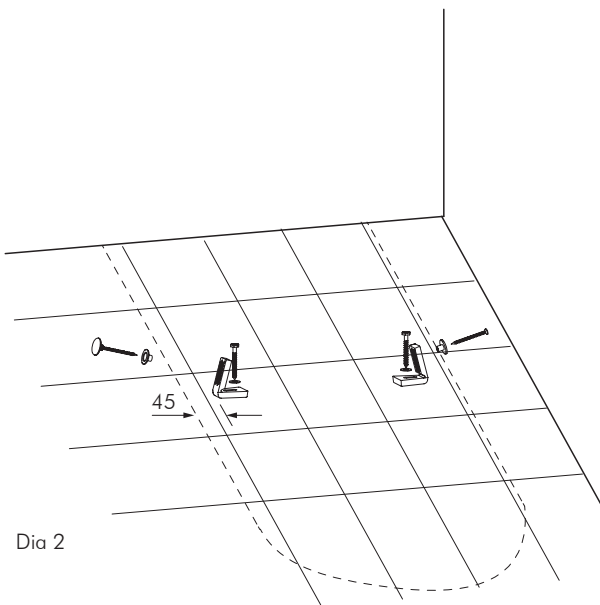
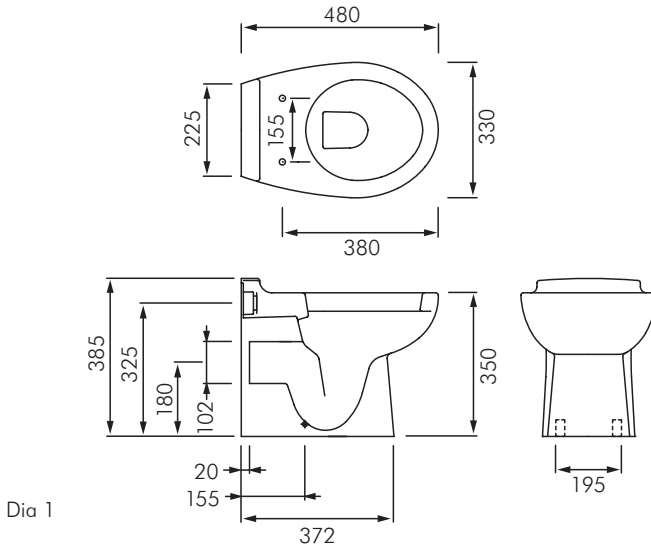



**MACDONALD
INDUSTRIES LIMITED**

Auckland (Head Office)

20 Carr Rd, Three Kings

Auckland 1041

P: 09 624 1115

F: 09 624 1110

E: sales@macdonaldindustries.co.nz

Wellington

P: 04 569 8033

F: 04 569 8066

Christchurch

P: 03 348 2356

F: 03 348 2376

www.macdonaldindustries.co.nz