

## **RA-LE2110**

### LENA CHILD WALL HUNG BASIN

---

**RAK**  
CERAMICS



#### **PACK INCLUDES**

- RA-LE2110 wall hung basin with 1 tap hole without overflow
- Fixing Kit ref RA-FS31SL1
- Installation Instructions
- Guarantee Form

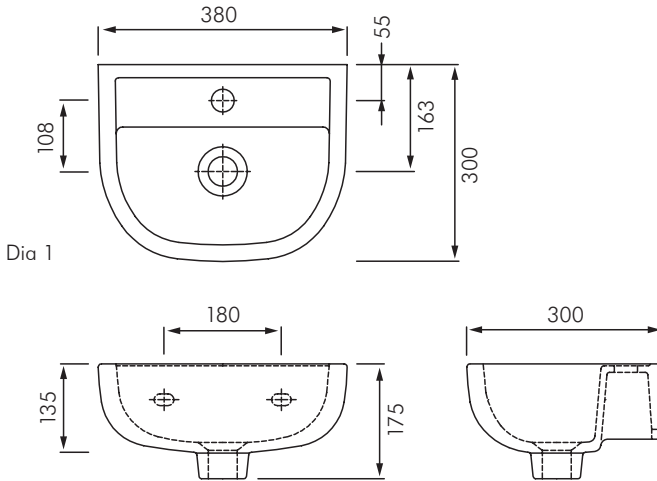

## PRE LINING

- Ensure walls are nogged to allow secure fixing at points for basin as shown in Dia 1. to suit preferred height of basin (nominal 700mm from FFL to top of basin).
- Install waste pipe inlet to suit preferred waste trap.
- Fit wing backs in wall to suit tap specified.
- Remove basin from wall.

## POST LINING

- Pre-fit tap to basin (if applicable).
- Fix basin to wall using plastic bush and screws supplied.
- Apply a bead of mould resistant silicon sealant around basin where it meets the wall.
- Fit 32mm basin waste and waste trap (not supplied).
- Connect tap to water supply as necessary.



**MACDONALD  
INDUSTRIES LIMITED**

### Auckland (Head Office)

20 Carr Rd, Three Kings

Auckland 1042

P: 09 624 1115

F: 09 624 1110

E: [sales@macdonaldindustries.co.nz](mailto:sales@macdonaldindustries.co.nz)

### Wellington

P: 04 569 8033

F: 04 569 8066

### Christchurch

P: 03 348 2356

F: 03 348 2376

[www.macdonaldindustries.co.nz](http://www.macdonaldindustries.co.nz)