

RA-PH3100 PHOENIX WALL HUNG URINAL

RAK
CERAMICS

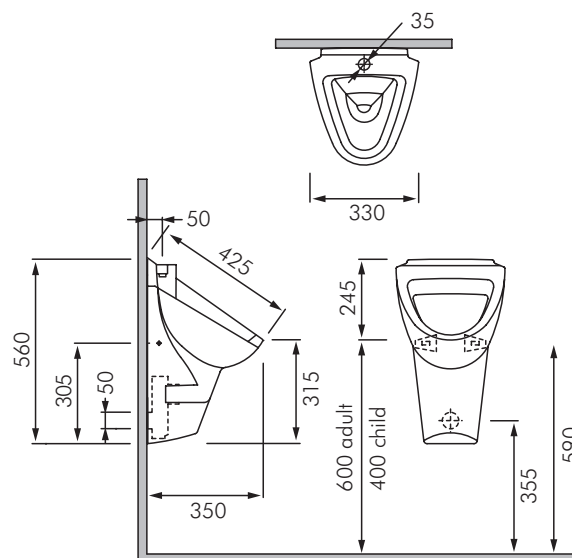

DESCRIPTION

The Phoenix wall hung urinal is a timeless design that will suit all bathrooms. The Phoenix is available with both rear inlet & top inlet water connections, and has a concealed waste trap.

Care should be taken to ensure correct flushing volumes are maintained to ensure complete hygiene and complete rinsing of waste pipes.

Colour: White only.

Inlet connection: 1/2" BSP inlet connector included with RA-PH3200. RA-PH3100 requires flush valve connection pipe to be supplied with valve set. Refer Installation Instructions for details.

Waste outlet: Waste trap included. Plumber to install Ø50 waste (socket end to urinal) pipe in wall.

Water pressure range: 100-500kPa.

Fixings: FS37UK fixing kit included.

Dimensions: All dimensions in mm. tolerance $\pm 5\%$ for below 200mm and $\pm 3\%$ above 200mm.

Flushing: Refer separate literature for our RAK electronic flush valves, Delabie flush valves and Zurn flush valves.

MODELS

RA-PH3100 - RAK Phoenix top inlet urinal complete with fixing kit.

RA-PH3200 - RAK Phoenix rear inlet urinal complete with fixing kit.