

RA-RE1324
RESORT WALL HUNG TOILET PAN

RAK
CERAMICS



PACK INCLUDES

- RA-RE13200P wall hung toilet
- RA-RE145400 soft close Urea seat & lid
- Installation Instructions
- Guarantee Form
- RA-GL08K fixing kit

OPTIONS

- Inwall mounting bracket - RA-WHB-UNI



MACDONALD
INDUSTRIES LIMITED

Auckland (Head Office)

20 Carr Rd, Three Kings
Auckland 1042
P: 09 624 1115
F: 09 624 1110

E: sales@macdonaldindustries.co.nz

Wellington

P: 04 569 8033
F: 04 569 8066

macdonaldindustries.co.nz

Christchurch

P: 03 348 2356
F: 03 348 2376

NOTES

- Inspect all items thoroughly immediately on receipt to ensure it meets your requirements.
- Inspect product for defects prior to installation. MacDonald Industries will not be responsible for any claims related to replacements after a product has been installed.
- Ensure wall support bracket has been installed to the correct height as required to meet the contract specification and NZ Building Code G1.
- Check water pressure does not exceed 500kPa. Fit pressure reducing valve if necessary.
- Check water inlet / waste outlet positions are correct for the WC supplied according to the measurements in Dia. 1.
- All measurements provided are based on finished wall/floor.
- Installation must only be completed by a registered plumber in accordance with AS/NZS3500 requirements.
- Correct wall support for any wall hung WC is essential and is totally the responsibility of the contractor. MacDonald Industries will not accept any claim for damages caused by inadequate wall structures, materials or incorrect support for the WC.

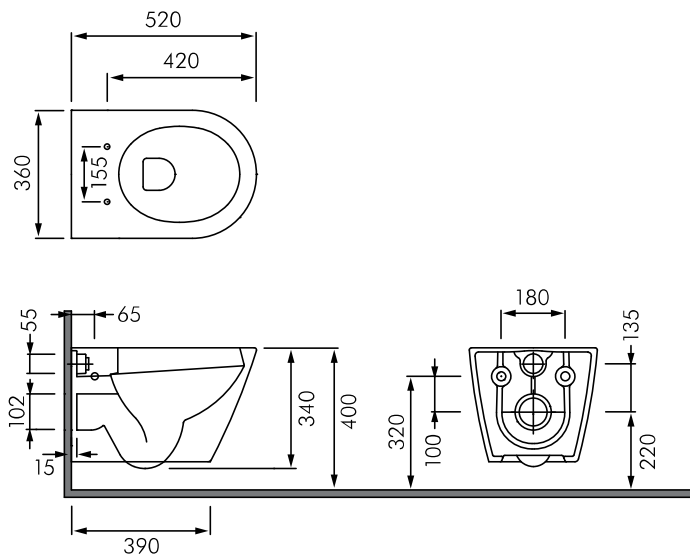

Dia 1

PRE-LINING INSTALLATION

- Fit wall bracket according to manufacturers instructions ensuring the through wall fixing bolts are set to a height to allow the pan to meet the height required for the contract.
- Ensure through wall bolts are at the correct spacing to suit the WC mounting holes.
- Complete installation of inwall cistern or flushing valve to manufacturers specification allowing the horizontal pipe to extend sufficiently to meet the pan horn.

POST-LINING INSTALLATION

- Trim horizontal flush pipe as necessary and fit Kee seal.
- If mounting frame is supplied with tile insulation panel, fit to wall.
- Slide WC onto fixing bolts and water/waste pipes, tighten nuts and fit covers.
- Trim around tile insulation panel with sharp craft knife.
- Apply bead of flexible mould resistant silicon around WC.
- Where inwall cistern has been used, flush line thoroughly before final connection to cistern according to manufacturers instructions.
- Where inwall flush valve has been installed, remove internals of flush valve and open stop cock to flush debris/air from flushing line for at least 1 minute, reassemble and test flush.

SPARES

- Toilet fixing kit - RA-GLO8K
- Soft close seat fixing kit - RA-RE1454HN