

---

## FLUSHING VALVES

There are many varieties of flushing valves and those listed below are examples of those offered by MacDonald Industries Ltd, suitable for use with the Venice urinals. For details on each type refer appropriate tech data sheet.

### RA-VE3200

Delabie recess mounted timed flow flush valves. Connection from valve to inlet connector by plumber:

**DE777 130** - Temposoft flush valve with 130dia escutcheon plate. 1L flush adjustable. 7 Second flush.

**DE779 128** - Tempostop flush valve with 130dia escutcheon plate. Min 1.7L flush adjustable.

RAK recess mounted electronic flush valve:

**RA-FS10-6V** - Sensor activate flush valve, battery powered. Automatically flushes urinal after use. 1L adjustable.

**RA-FS10-230V** - As above but with 230V/6V power supply. 230V electrical connection by electrician.



**MACDONALD  
INDUSTRIES LIMITED**

#### Auckland (Head Office)

20 Carr Rd, Three Kings

Auckland 1042

P: 09 624 1115

F: 09 624 1110

E: [sales@macdonaldindustries.co.nz](mailto:sales@macdonaldindustries.co.nz)

#### Wellington

P: 04 569 8033

F: 04 569 8066

#### Christchurch

P: 03 348 2356

F: 03 348 2376

[www.macdonaldindustries.co.nz](http://www.macdonaldindustries.co.nz)

**RA-VE3200**  
VENICE WALL HUNG URINAL

**RAK**  
CERAMICS

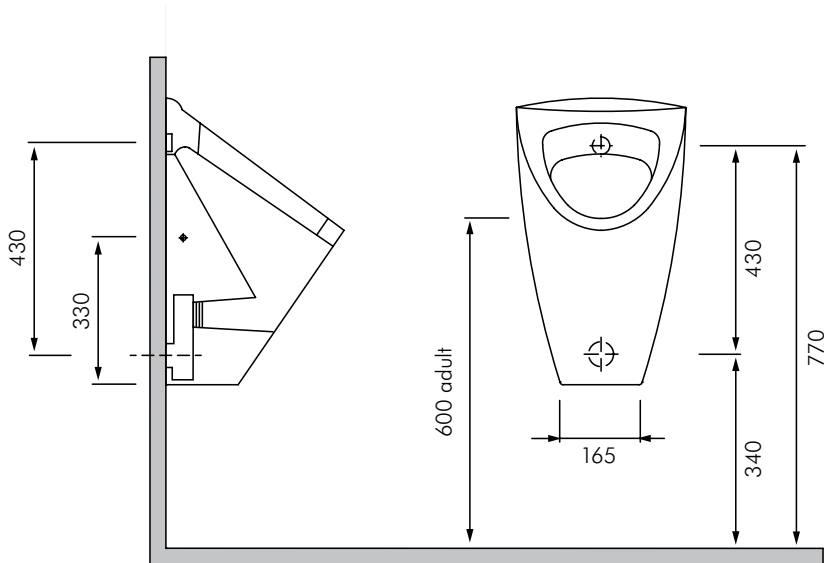

Reduce height by 200mm  
for a child installation.

---

## PRE LINING

Ideal pressure range: 100 - 500kPa

Pipe up to urinals according to the drawings (pg 1) to suit the model of Venice urinal supplied and to suit the flushing system specified. Dimensions shown are based on urinal being installed for adults, adjust height dimensions if urinal is lowered for children (nominal 200mm).

Walls should be nogged to suit fixing bracket positions shown.

**Carefully check what each urinal flush valve is supplied with as this can vary from product to product.**

Waste trap supplied with each urinal requires a **50mm PVC socket** be fitted flush with the wall in the outlet position shown.

Water inlet connection requires a rubber Kee Seal connector with a 1/2" BSP connection.

**RA-VE3200** - Urinals are supplied with a proprietary inlet connector. Where appropriate, these should be screwed into a 1/2" wingback in the wall leaving the keeseal protruding from the wall no less than 15mm. Piping from recessed flush valve to wingback is plumbers care.

## **POST LINING**

Fix wall mounting brackets to wall in required position.

Back inlet urinals will require inlet connector to be screwed into wingback, protruding no more than 15mm from finished face wall.

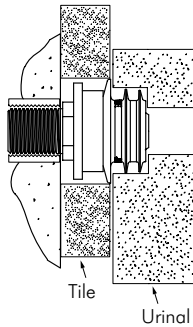

Waste trap is supplied with a rubber keeseal which must be fitted to outlet of trap. Fit waste trap to outlet of urinal and present urinal back to wall, pushing the waste outlet into the 50mm PVC socket. Some trimming of waste outlet pipe may be necessary to achieve correct fit.

Once all connections have been made and flushing valve is working correctly, apply bead of white silicon around urinal to achieve seal to wall.