

## RA-VE3200 VENICE WALL HUNG URINAL

**RAK**  
CERAMICS

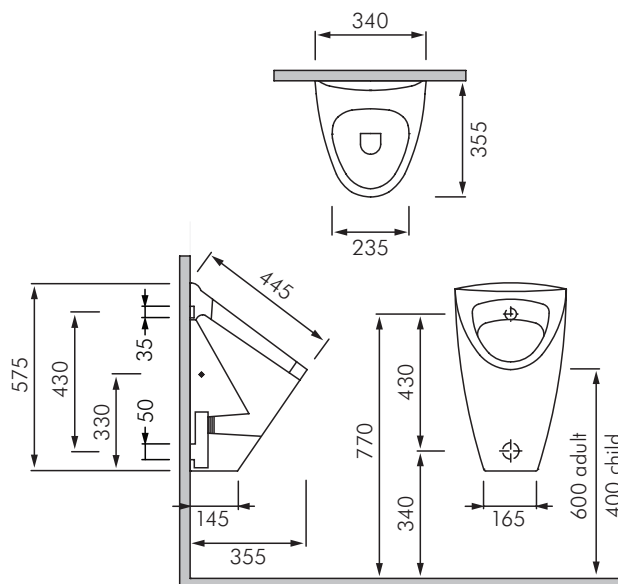

### DESCRIPTION

The Venice urinal has unique and exotic design characteristics. The overall appearance and broad dimensions make Venice a luxury, bold statement.

The Venice urinal has a rear inlet and has a rear outlet for concealed trap.

Care should be taken to ensure correct flushing volumes are maintained to ensure complete hygiene and complete rinsing of waste pipes.

**Colour:** Alpine white only.

**Inlet connection:** 1/2" BSP inlet connection included.

**Waste outlet:** Waste trap included. Plumber to install Ø50 waste (socket end to urinal) pipe in wall

**Water pressure range:** 100-500kPa.

**Fixings:** FS37UK wall fixing kit included.

**Dimensions:** All dimensions in mm. Tolerance  $\pm 5\%$  for below 200mm and  $\pm 3\%$  above 200mm.

Refer to separate literature on Delabie and RAK recess mounted flushing systems.

### MODEL

**RA-VE3200** - RAK Venice wall hung urinal complete with fixings.