



MacDonald Rubbish and Linen Chutes

Rubbish and Linen Chutes for multi-storied buildings requiring efficient floor by floor removal of waste, recyclables or soiled linen.

Featuring:

- Wilkinson Chutes Co of America design – proven over 60 years
- Over 30 years experience in chute installation in New Zealand
- Galvanised or stainless steel
- Sanitising spray disinfecting system
- Electrical door interlock
- Automated recycling system and waste bins



**MACDONALD
INDUSTRIES LIMITED**

Soiled Linen Chutes

Linen chute allows efficient and economical collection of soiled linen from upper floors in multi-storied hotels, hospital and apartments to a centrally located discharge area on a lower floor.

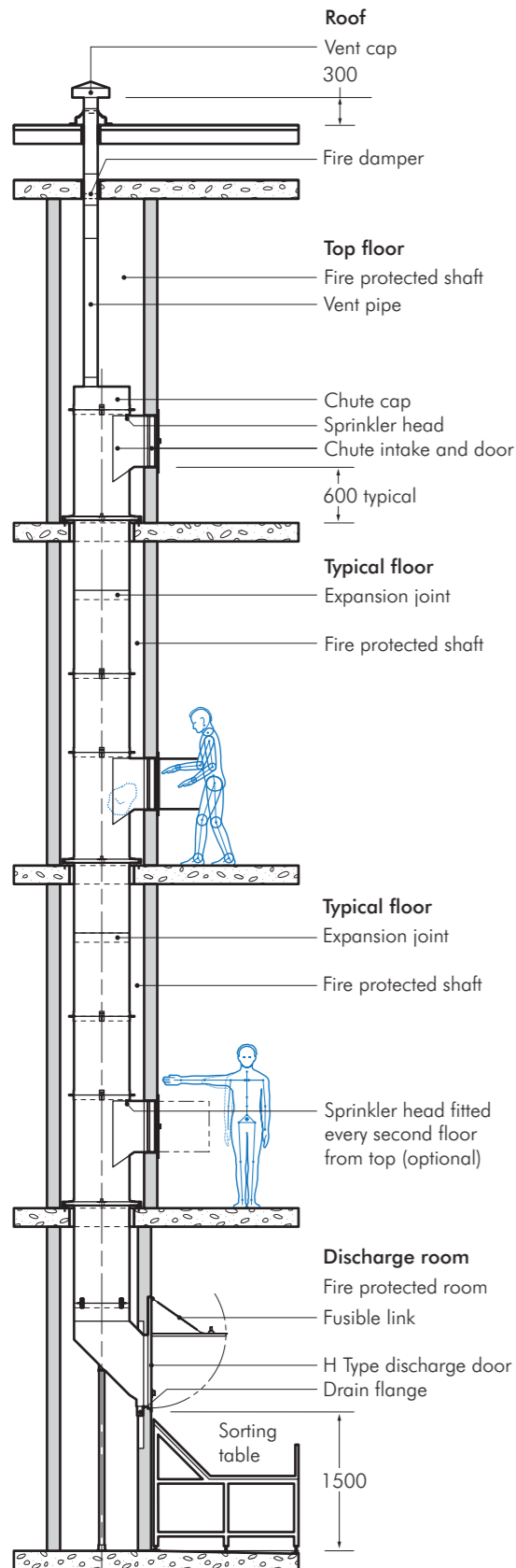

Linen Chute. H Type Discharge

Materials

1.6mm galvanised steel or 1.2mm Type 304 stainless steel.

Doors

- Stainless steel, side hinged (specify LH or RH hinged), hand operated, self closing. -/60/30 fire resistance (FRR) level meeting AS 1530.4 – 2014 when installed in accordance with instructions supplied to the builder at time of contract.
- Optional -/30/- FRR for use in fully sprinkled buildings (refer C/AS 2.3.13) subject to fire engineers approval. Also see Page 6.
- Hydraulic return strut ensures smooth quiet close, and easy opening.
- Stainless steel trim depicting use of chute.
- Normally installed 600 from FFL but can be installed as low as 150 from FFL if required.

Standard Features

- Noise reducing floor frame mounting pads.
- Fire sprinklers every second floor.
- Intumescent damper where vent passes through top of shaft wall.

Options

- Electrically interlocked doors allowing option of central locking system to prevent chute use during bin removal or chute sanitising. Also locks off other doors when one door is opened.
- Key operated cylinder locks.
- H or A Type discharge doors.

Fire Rating

Wilkinson chute intake doors have been tested in accordance with AS1530.4-2014 and test reports are available on request. The approval requires the chutes to be installed within a fire protected shaft wall and for the door/wall interface to be exactly as tested. Full details can be given on request. Any variation from this method of construction will render the fire rating void and fire rating tags will not be fitted.

Tests completed allow for either a -/60/30 FRR where the building is not fully sprinkled or -/30/- FRR where the building is sprinkled in accordance with either NZS4541 or NZS4515 (refer C/AS 2.3.13). Either rating should be approved by the fire engineer in accordance with the buildings design criteria and specified accordingly.

As the discharge doors are not fire rated, the discharge room should be built as part of the continuous fire cell, including the shaft.

The top of the shaft should be capped to enclose the fire cell and where the chute vent passes through that cap, a Firepro intumescent damper is fitted.

C/AS2 4.11.5 requires sprinkler heads to be fitted at the top of the chute and in the discharge room on non sprinkled buildings, however we recommend sprinklers every second floor as per Wilkinson design criteria.

Chute Diameter	Door Size
500mm*	450 x 450mm
600mm	530 x 530mm
700mm	530 x 530mm
800mm	530 x 530mm

* 500mm chute should only be used for loose linen. 600mm chute is generally regarded as minimum size. All dimensions are rounded for convenience.

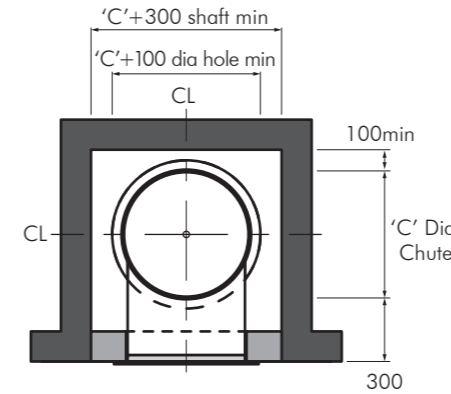

Plan drawing of shaft dimensions

Discharge Doors

Wilkinson insulated discharge doors are permanently held open on a fusible link. They are not designed to be used as a means of "collecting" linen within the chute. Rather they are provided to assist in limiting the movement of fire from the basement to the upper floors. Note: Wilkinson discharge doors are built to the same standard as the intake doors but are considered non-fire rated. They must be installed in a suitably fire rated room forming part of the continuous fire cell up the building.

The type of discharge door used will depend on how the soiled linen is to be handled. Whilst traditional laundry rooms may have had in-house laundry facilities, the trend is to out-source.

H TYPE

The H Type discharge is commonly used where loose linen is discharged onto a sorting bench and transferred directly to a washing machine. Specify the sill height to suit the table (or trolley if preferred) - 1500 from FFL is typical. Door is top hinged, held open by wire strop fitted with fusible link - swings shut when fusible link is broken due to fire.

The door is designed to be built into a framed face wall in order to improve cleanliness and appearance. Although self supported on its support post it should not be regarded as "free standing".

A TYPE

The A Type is mostly used where the linen is either loose or bagged and is collected in a trolley or bin for transfer to another space within the building or to an outside facility.

Door is contained within a horizontally mounted steel frame. Door is held open by fusible link and will roll shut when fusible link is broken due to fire beneath.

Sanitiser Unit

Not common on linen chutes but if required see detail under Rubbish Chutes.

Work by others

- Roof penetrations and flashing around vent.
- Shaft wall around chute to GIB Shaft Wall design using timber framed walls in accordance with BRANZ fire test.
- Casting a round penetration in each floor 100mm larger than the chute diameter. Square holes need to be avoided.
- Any passive fire sealing to fire engineers requirements.
- Complete face wall around discharge door after chute installation.
- Water connection to sanitiser and sprinkler heads.
- Sound insulation wrap (if required).
- Electrical connection to control box for interlocked doors.
- Waste and drain connection on H Type discharge door.

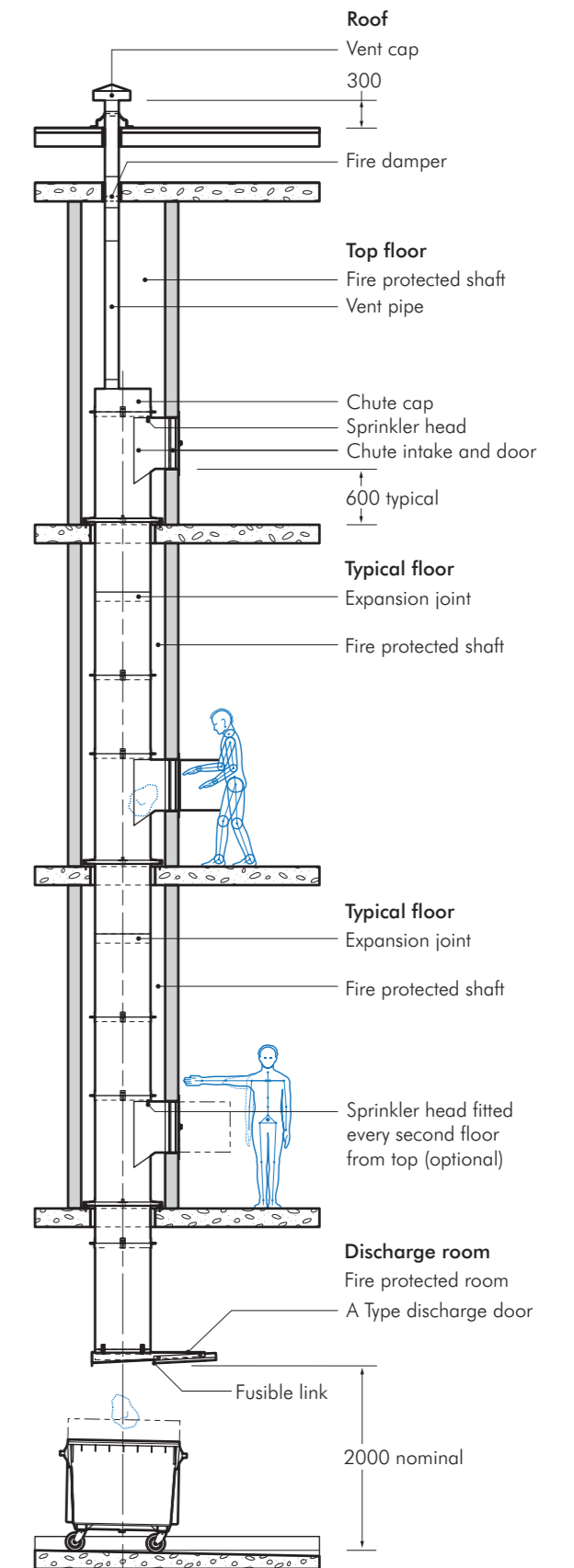

Linen Chute. A Type discharge

Rubbish Chutes

Rubbish chutes provides an efficient and hygienic method of waste removal in all types of multi-storied residential and commercial buildings. Rubbish chutes are the best way to consolidate waste and recyclables from around the building into a single location for easier collection.

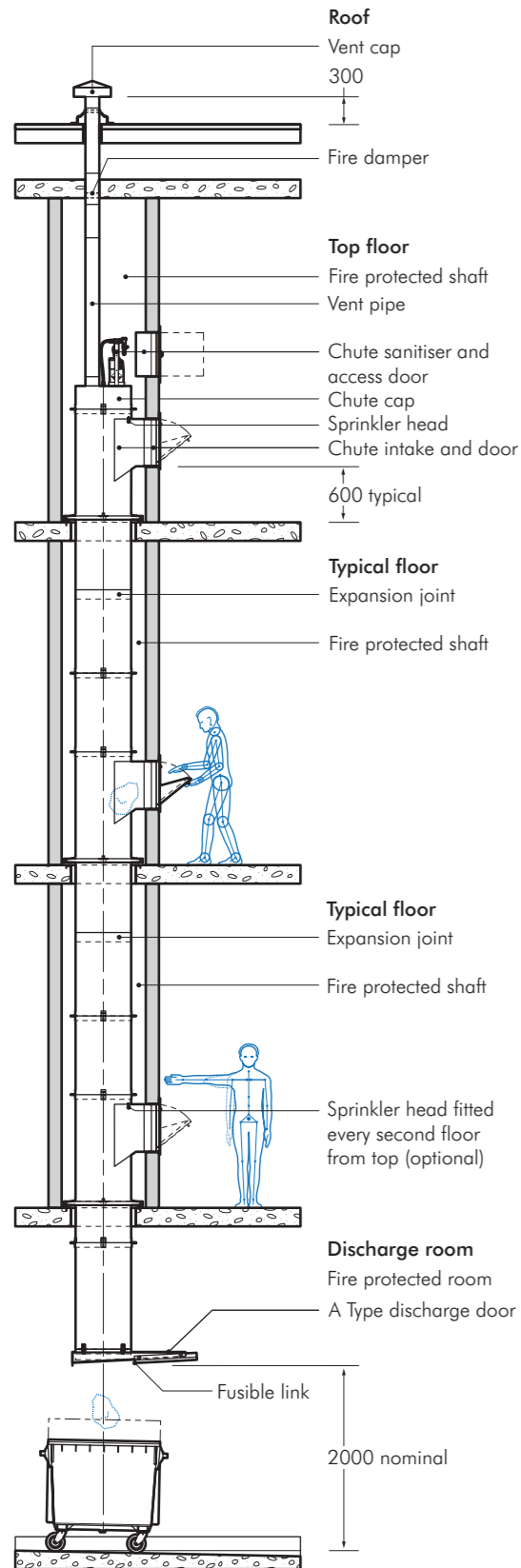

Rubbish Chute: A type discharge

Limitations

MacDonald/Wilkinson rubbish chutes are primarily designed for use in apartment buildings where small "kitchen tidy liner" type bags are used to dispose of waste. Loose waste should be avoided - particularly cardboard boxes which tend to expand and block chutes. If in doubt increase the size of the chute to 600 or even 700 dia. but retain the same size door.

Where a rubbish chute is to be used for commercial rubbish using larger rubbish bags, specify side hinged doors (linen chutes) for the levels that pertain and a minimum 600mm dia. chute.

Materials

1.6mm galvanised steel or 1.2mm stainless steel.

Doors

- Stainless steel, bottom hinged, hand operated, self closing. -/60/30 FRR meeting AS 1530.4 - 2014 when installed in accordance with instructions supplied to the builder at time of contract.
- Optional -/30/-FRR for use in fully sprinkled buildings (refer C/AS 2.3.13) subject to fire engineers approval. Also see Page 6.
- Hydraulic return strut ensures smooth quiet close, and easy opening.
- Stainless steel trim depicting use of chute.

Standard Features

- Noise reducing floor frame mounting pads.
- Fire sprinklers every second floor.
- Intumescent damper where vent passes through top of shaft wall.

Options

- Electrically interlocked doors allowing option of locking system to prevent chute use during bin removal or chute sanitising. Also locks off other doors when one door is opened.
- Key operated cylinder locks.
- Sanitising spray system.*
- Lockable side hinged doors, suitable for commercial office buildings or where waste is bagged.
- Waste recycling system (refer page 8).
- Sound insulation wrap.

* Recommended

Chute Diameter	Door Size
500mm	450 x 450mm
600mm	450 x 450mm
700mm (commercial)	450 x 450mm

Larger chutes possible but intake door would remain the same.

Work by others

- Roof penetrations and flashing around vent.
- Shaft wall around chute to GIB Shaft Wall design using timber framed walls in accordance with BRANZ fire test.
- Casting a round penetration in each floor 100mm larger than the chute diameter. Square holes need to be avoided.
- Any passive fire sealing to fire engineers requirements.
- Water connection to sanitiser and sprinkler heads.
- Sound insulation wrap (if required).
- Electrical connection to control box for interlocked doors.

Fire Rating

Wilkinson chute intake doors have been tested in accordance with AS1530.4-2014 and test reports are available on request. The approval requires the chutes to be installed within a fire protected shaftwall and for the door/wall interface to be exactly as tested. Full details can be given on request. Any variation from this method of construction will render the fire rating void and fire rating tags will not be fitted.

Tests completed allow for either a -/60/30 FRR where the building is not fully sprinkled or -/30/- FRR where the building is sprinkled in accordance with either NZS4541 or NZS4515 (refer C/AS 2.3.13). Either rating should be approved by the fire engineer in accordance with the buildings design criteria and specified accordingly. Also see Page 6.

As the discharge doors are not fire rated, the discharge room should be built as part of the continuous fire cell, including the shaft.

The top of the shaft should be capped to enclose the fire cell and where the chute vent passes through that cap, a Firepro intumescent damper is fitted.

C/AS2 4.11.5 requires sprinkler heads to be fitted at the top of the chute and in the discharge room on non sprinkled buildings. Standard Wilkinson design advocates sprinkler heads at the top intake on the top floor and every second floor thereafter. Heads are supplied loose complete with protective cage, and should be fitted off by the fire sprinkler installer.

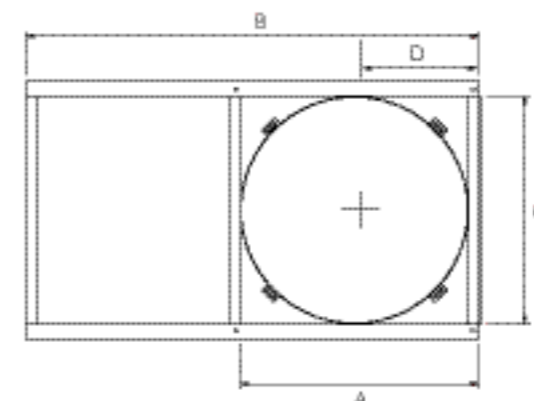

A Type discharge

Discharge Doors

Wilkinson insulated discharge doors are permanently held open on a fusible link. They are not designed to be used as a means of "collecting" waste within the chute. Rather they are provided to assist in limiting the movement of fire from the basement to the upper floors. **Note: They are built to the same standard as the intake doors but are considered non-fire rated - must be installed in a suitably fire rated room forming part of the continuous fire cell up the building.**

A TYPE

The A Type is used where the waste is collected directly beneath the chute in a bin or compactor.

Door is contained within a horizontally mounted steel frame, is held open by fusible link, and will roll shut when fusible link is broken due to fire beneath.

A Type discharge doors are normally set approximately 2000mm from FFL in order to clear head height. If small 240L mobile garbage bins are to be used this height should be lowered to 1500mm but with sufficient clearance to avoid waste obstructing the discharge door.

H TYPE

Not recommended for use with rubbish chutes due to the likelihood of damage/safety concerns.

Sanitiser Unit

The sanitiser unit is positioned above the top floor intake and is accessed through a separate door (same design as the side hinged intake door)

The sanitiser unit allows the maintenance staff to spray the chute with disinfecting solution periodically and then repeat with clean water. It is not a replacement for good housekeeping and periodic hand cleaning of intake doors and surrounds should be standard practice.

When used with the A Type discharge a considerable amount of water/solution will discharge directly on the floor, therefore walls/floors in the discharge room should be covered and suitably sealed to allow easy cleaning and limit damage. Hose down facilities should be available in the discharge room.

When installed with the H Type discharge door, the discharge door is closed allowing the waste water to drain through the base of the door to waste.

Chute Diameter A	Length B	Length C	Length D
500mm	1115mm	590mm	282mm
600mm	1320mm	692mm	333mm
700mm	1520mm	795mm	384mm

Designing for Chutes

Acceptable Solutions

The following are sections of Acceptable Solutions C/AS2 covering issues with regards to chutes and fire ratings.

C/AS2

2.3.13(b)

Insulation ratings are not required to apply to: Elements where sprinklers are installed throughout the building, in accordance with either NZS 4541 or NZS 4515 as appropriate

Table 2.4

Risk Group SM requires 60min life rating for unsprinkled buildings and 30min life rating for sprinkled buildings

4.11.5

Solid waste and linen chutes which pass from one firecell to another shall be protected shafts or contained within a protected shaft.

In unsprinkled buildings each chute shall be equipped with automatic sprinkler heads connected to any water supply pipe capable of meeting the minimum design criteria for the selected sprinkler head. These sprinklers shall be installed at the top of each chute and in the space into which the chute discharges. The minimum residual pressure in the water supply pipe shall be 50 kPa with two sprinkler heads operating.

4.11.6

Solid waste and linen chutes shall have no inlet or discharge openings within an exit way.

4.16.1

If activities within a building require openings in fire separations or smoke separations, closures to those openings shall have the insulation and smoke control performance as required by Table 2.4. Because Wilkinson chute doors do not have any smoke seals the room in which the intake door is situated must have an entrance door that has smoke seals fitted.

Protected shaft access panels

This relates to areas such as offsets in chutes where an access panel may be required to access the chute to clear blockages

4.16.10

Access panels to protected shafts shall have the fire resistance performance as required by Paragraph 4.16.1 and shall be capable of being opened only with a special tool.

Chute Sizes

As a rule of thumb it is better to oversize the chute and undersize the door, particularly with rubbish chutes. This helps reduce the likelihood of blockages.

Where a -/60/30 FRR door is required considerable changes are made to the internal structure of the door frame to allow it to pass the insulation rating. The sizes shown are the door leaf size - the actual door opening will be slightly smaller than these dimensions.

Smoke Seals

Acceptable Solutions ask that elements in most buildings where chutes are installed are rated to -/60/30FRR (unsprinkled) or -/30/-SM (sprinkled). The Building Code asks that chute doors are not accessible from exit ways and as such the intake doors should be contained within a cleaners room (linen) or specific waste room in order to separate them from other fire cells. Fitting smoke seals to chute doors is not possible due to their design, however fitting smoke seals to door sets separating the room from the exitway complies with the regulations. Therefore ensure the outer door to the room has smoke seals fitted in order to comply.

Chute Offsets

Offsets in any chute should be avoided where possible and under no circumstances will we install offsets greater than 30°. Offsets must be gusseted and supported by a structural post in order to take the impact of heavy bags. Access panels on the top side of the offset must be complimented by fire rated access doors into the shaft to enable clearing of blockages. This adds considerably to the cost but is unavoidable.

As an example a 600 dia chute installed in a 3m floor to floor height can only offset a maximum of 1 m.

MacDonald Industries takes no responsibility for blockages in chutes due to incorrect use, and offsets can be a prime cause of blockages.

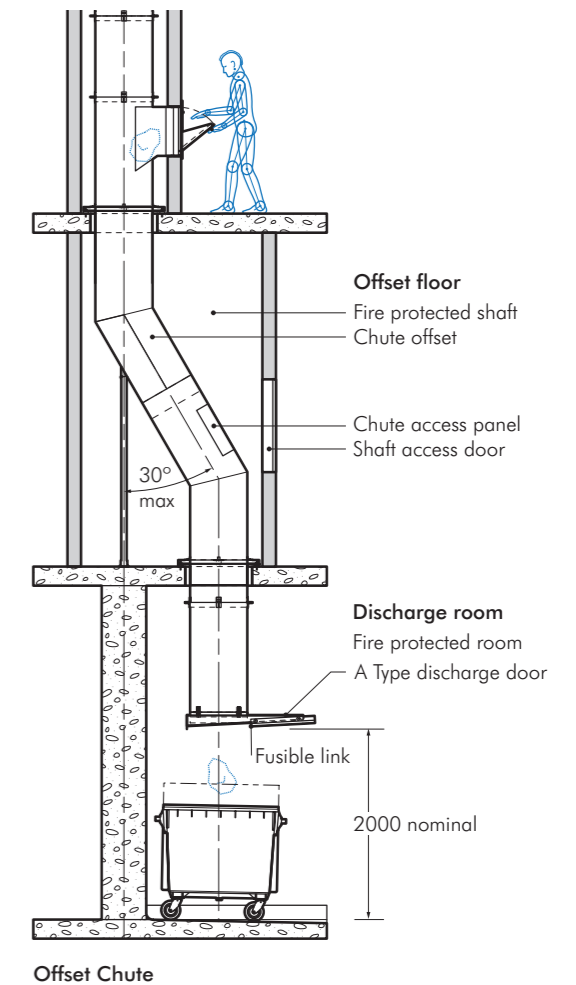

Waste Recycling

A common practice is to separate waste from recyclables and this can be done in one of two ways.

Bi-Sorter

The Wilkinson Bi-Sorter allows the user to direct the waste to one of two bins in the discharge room - see Page 8 for details). Ideal for taller buildings where it is more cost effective than separate chutes. The Bi-sorter uses electrically interlocked doors which provide the benefit of safety (door lock off from the basement) when changing the bins over.

Separate Chutes

Separate chutes for rubbish/recyclables eliminates the higher cost of the Bi-Sorter but increases the footprint required for the chutes.

Glass is an issue for recycling as waste stations don't like accepting broken glass. Keeping glass unbroken is almost impossible with chutes and it is often better to locate glass recycling stations on each level or in the basement of the building.

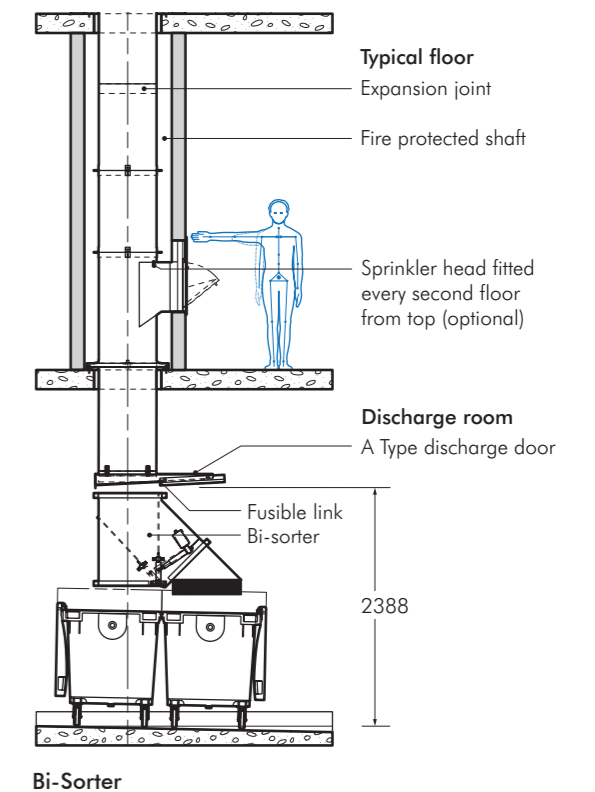

Automated Recycling Systems

Electronic systems allows the user to select the type of waste to be deposited with a multi-sorter diverting the waste to the appropriate bin. This eliminates the burden of carrying recyclable materials to another location.

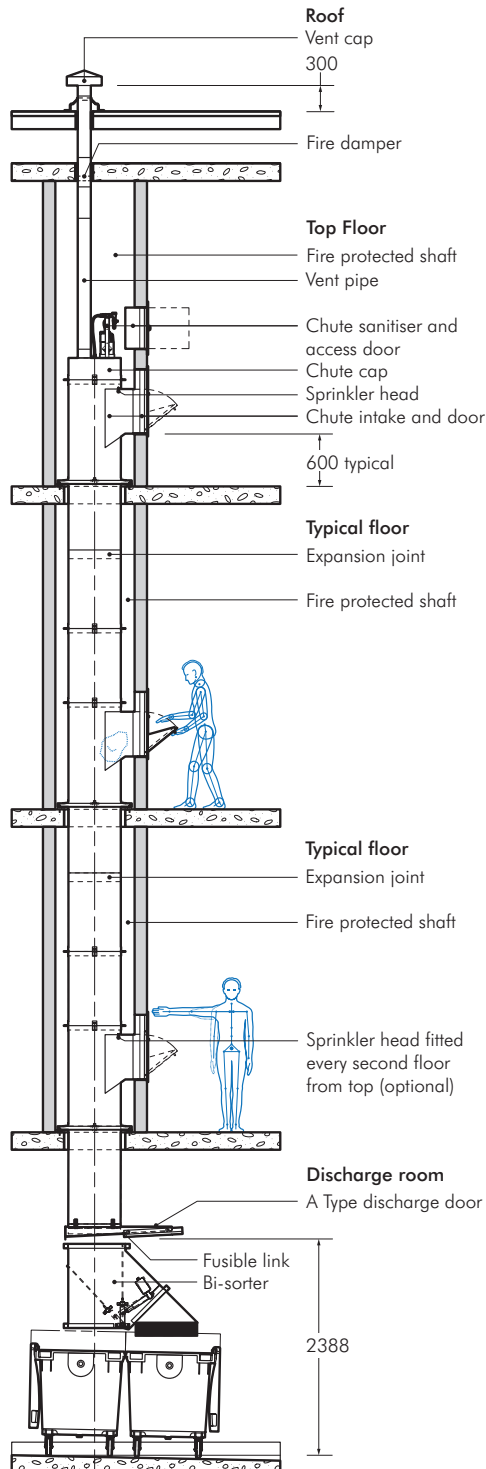

Automated recycling chute

MacDonald/Wilkinson Automated Recycling System

Optional recycling system provides engineered, site specific, control system for handling waste from apartments and office buildings.

- Electrically interlocked doors prevent simultaneous use of chute.
- Allows user to choose into which container their waste will be directed.
- Bi-sorter or Tri-sorter in discharge room directs waste into either waste compactor or waste bins.
- Eliminates the cost associated with floor to floor recycling collection.
- Increases recycling rate, reducing waste costs.
- Relieves residents from carrying recyclables to basement storage facility.
- Automatically defaults to "waste" position after use.
- Safety lockout of chute during bins change over.

Refer to MacDonald Industries Ltd for further information and design assistance.

Waste Compactors and Bins

MacDonald Industries have a range of waste compactors and bins to suit every application. Choosing a means of collection to suit the application depends on a number of criteria:

- Does the building have a full time person?
- Can a bin be changed regularly?
- How many apartments/staff are in the building?
- Does the nature of the waste require regular bin changes?

Options on waste collection include:

- Mobile garbage bins 240L – 1100L.
- Rotary compactors.
- Stationary compactors.

Contact one of our staff for assistance in choosing the best solution to your waste problem.

