

# WATER GUARD

## Series 3 - Urinal Water Control

### When **NOT USING** a Cistern Tank



#### **1.0 CONTENTS OF STANDARD WATER GUARD INSTALLATION KIT**

- 1.1 1 x Water Guard control unit with adjustable mounting bracket and Clipsal 4 pin plug.
- 1.2 1 x Clipsal No 408 4 pin socket.
- 1.3 1 x set of Installation Instructions.
- 1.4 1 x 13mm 230V AC solenoid valve (if ordered).
- 1.5 1 x Guarantee form.

#### **2.0 GENERAL DESCRIPTION**

Water Guard consists of two main items. A sensor control unit and a solenoid valve. The combination allows controlled flushing of mens urinals to prevent unnecessary water wastage.

#### **3.0 OPERATING PRINCIPLE**

On detection of a person stepping up to the urinal, the Water Guard will initiate a flush after a delay period. The delay period is set on site to suit the client's needs. Once the flush has finished, a new cycle will not occur until another person is detected.

Water Guard is programmable to suit individual customers needs and the options are shown in Section 6



**MACDONALD  
INDUSTRIES LIMITED**

#### **Auckland (Head Office)**

20 Carr Rd, Three Kings  
Auckland 1041  
P: 09 624 1115  
F: 09 624 1110  
E: sales@macdonaldindustries.co.nz

#### **Wellington**

P: 04 569 8033  
F: 04 569 8066

#### **Christchurch**

P: 03 348 2356  
F: 03 348 2376

[www.macdonaldindustries.co.nz](http://www.macdonaldindustries.co.nz)

## 4.0 PLUMBING INSTALLATION

This Water Guard is pre-set to be installed in conjunction with a cistern tank. IT IS YOUR RESPONSIBILITY TO ENSURE THE SWITCHES ARE RE-SET TO SUIT AN INSTALLATION WITHOUT A CISTERN. Refer Section 6.0

All plumbing should be completed by a qualified tradesman.

There are two methods of installing Water Guard without a cistern tank.

- a) Using a non potable supply tank - See Section 4.1
- b) Using a Zurn mains pressure flushing valve (see separate literature) - refer Section 4.2

Under no circumstances should a urinal be installed without complying with current building regulations and/or territorial approvals. If in doubt contact your local Building Authority. The methods described in Sections 4.1 and 4.2 comply.

### 4.1 Installations Using Supply Tanks

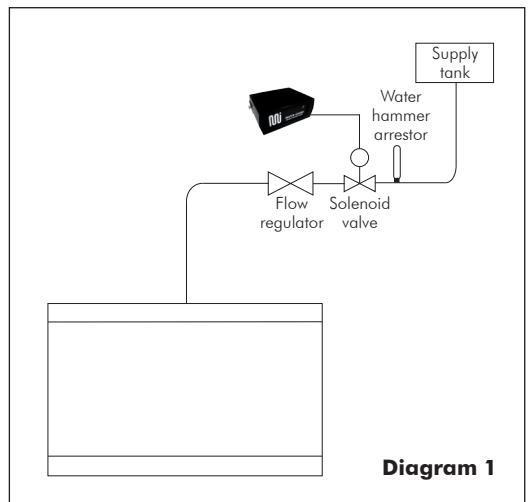
Provided the roof tank complies with backflow protection requirements, the potable water is protected by the airgap in the tank. Water Guard will control the flushing directly without the need for subsequent cistern tanks.

The pipe and valve sizing should be designed by a suitably qualified person, in order to achieve a flush volume of 2.5L/bowl (or 4.5L per stall of slab urinal).

1 stall = 600mm urinal width. Water Guard will open the solenoid valve for either 7 or 15 seconds (refer Section 6.0) We recommend bowls are flushed for 7 seconds and slab urinals for 15 seconds.

Solenoid valves can be supplied as 13, 19 and 25mm sizes as standard. All operate in the 10 - 1000kPa range but we recommend setting pressure within the 300 - 400kPa range for optimum performance. Use a Wilkins Model NR3 pressure reducing valve if necessary. Where very low pressures exist, ensure pipe sizing is sufficient to compensate. Water pressure should not be less than 100kPa.

Valves should be assembled as per Diagram 1



#### 4.2 Installation Using ZURN Flush Valves

Water Guard can be installed on mains pressure water supply when installed in conjunction with a Zurn mains pressure flush valve. The product is supplied as a complete kit and is known as either a Z6190-WG or Z6195-WG depending on the urinal size. Separate installation instructions are supplied with these models.

#### 4.3 Commissioning

Once the electrician has wired up the Water Guard, it is necessary to ensure the flushing function is correct.

Check that the switch setting has been altered to suit the client's needs and/or urinal style. Refer Section 6

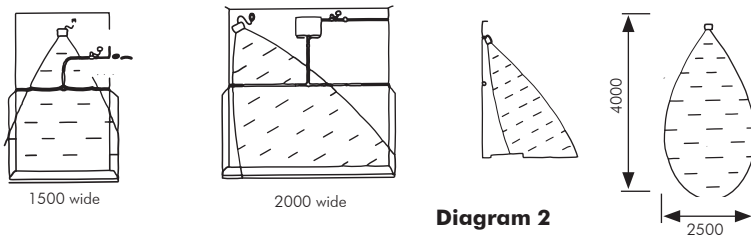
Press the re-set button on the back of the Water Guard. The solenoid valve should open for 2 seconds and then close. Pass your hand in front of the Water Guard. The LED on the front should flicker when detecting movement and after 10 seconds repeatedly switch ON and OFF every second for the duration of the delay time. Wait for the chosen delay period - the solenoid should open for the chosen flush time of 7 or 15 seconds.

### 5.0 ELECTRICAL INSTALLATION

Electrical work should be carried out by a registered electrician.

The control unit should be positioned, if possible to detect only people using the urinal.

Detection field patterns are as per Diagram 2, but smaller "lobes" of detection can occur outside this main lobe.



Avoid pointing the control unit towards hallways or other areas where traffic patterns may encourage false triggering. Remember, Water Guard will detect through walls and ceilings up to a maximum of 4m.

Where there are multiple urinals and Water Guards, avoid pointing the control unit towards other urinals as water movement can also cause false triggering.

The control unit can be mounted above a ceiling for out of sight installation, provided the thickness of the ceiling does not exceed 15mm and it is a non-conductive material such as Gibboard, Hardiflex, plastic or glass. Materials such as sheet metal, foil or foil backed boards and wire reinforced glass should be avoided. See Diagram 3 for clearances.

## 5.0 ELECTRICAL INSTALLATION (cont)

The Clipsal 4 pin socket should be mounted adjacent to the controller and wired to mains as per Diagram 4. Removal of the plug may void warranty offers.

When the controller is plugged in, the red LED on the front of the controller should come on and flicker when movement is detected. Adjust the position of the controller to achieve suitable detection.

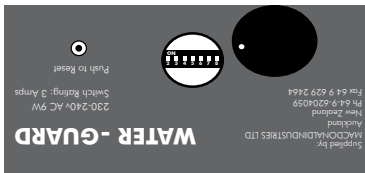
## 6.0 OPTIONS

Located on the back panel of the control unit is a small circular plate. Behind this is a series of 8 switches which give you the option of changing the flush cycle to suit your client's needs. There are 3 sections to these programme options;

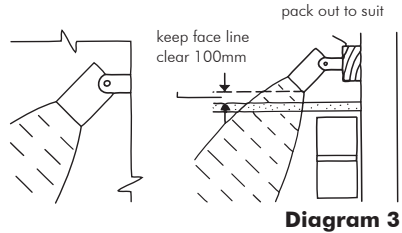
**a) After Hours Flushing:** Gives the option of regular after hours flushing to reduce the likelihood of trap dry-out.

**b) Delay After Detection:** Sets the delay time from time of detection to time of flush. Should be typically set to 4 or 5 minutes

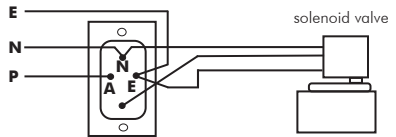
**c) Flush Time:** 7 seconds for bowl urinals, 15 seconds for slab urinals



**READ SWITCHES THIS WAY UP**



**Diagram 3**



**Power**  
**230V AC 50hz**  
**Max Current 3A**

**Diagram 4**

	1	2	3	4	5	6	7	8
<b>Must be up</b>	▼ △	△ ▼	△ ▼	△ ▼	△ ▼	△ ▼	△ ▼	△ ▼
<b>After Hours Flushing</b>								
24 hours		△	△					
12 hours		▼	△					
6 hours		△	▼					
OFF		▼	▼					
<b>Delay After Detection</b>								
1.5 minutes				▼	▼	▼		
3 minutes				△	△	▼		
4 minutes				▼	▼	△		
5 minutes				△	△	△		
15 minutes				▼	△	△		
30 minutes				△	△	△		
<b>Flush Time</b>								
7 seconds							▼	△
15 seconds							△	△

### RECOMMENDED SETTING

△ ▼ ▼ △ △ ▼ △ △ △  
**1 2 3 4 5 6 7 8**

**Diagram 5**

# WATER GUARD

## Series 3 - Urinal Water Control

When used **WITH** a Cistern Tank



### 1.0 CONTENTS OF STANDARD WATER GUARD INSTALLATION KIT

- 1.1 1 x Water Guard control unit with adjustable mounting bracket and Clipsal 4 pin plug.
- 1.2 1 x Clipsal No 408 4 pin socket.
- 1.3 1 x set of Installation Instructions.
- 1.4 1 x 13mm 230V AC solenoid valve (if ordered).
- 1.5 1 x Guarantee form.

### 2.0 GENERAL DESCRIPTION

Water Guard consists of two main items. A sensor control unit and a solenoid valve. The combination allows controlled flushing of mens urinals to prevent unnecessary water wastage.

### 3.0 OPERATING PRINCIPLE

On detection of a person stepping up to the urinal, the Water Guard will initiate a cycle of flushing. If the Water Guard is installed as pre-set, then flushing will occur approximately 90 seconds after detection and again 30 minutes later irrespective of the number of people using the urinal during the "cycle". Once the cycle has finished, a new cycle will only commence when another detection is made.

Water Guard is programmable to suit individual customers needs and the options are shown in Section 6



**MACDONALD  
INDUSTRIES LIMITED**

#### **Auckland (Head Office)**

20 Carr Rd, Three Kings  
Auckland 1041

P: 09 624 1115

F: 09 624 1110

E: [sales@macdonaldindustries.co.nz](mailto:sales@macdonaldindustries.co.nz)

#### **Wellington**

P: 04 569 8033

F: 04 569 8066

#### **Christchurch**

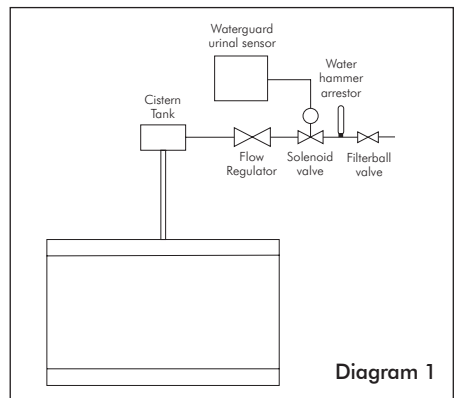
P: 03 348 2356

F: 03 348 2376

[www.macdonaldindustries.co.nz](http://www.macdonaldindustries.co.nz)

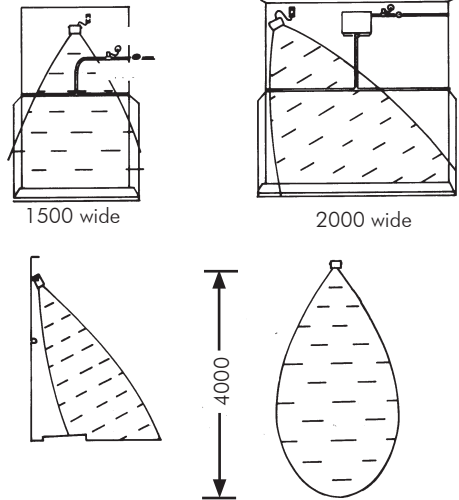
## 4.0 PLUMBING INSTALLATION

- 4.1 This Water Guard is pre-set to be installed in conjunction with a cistern tank fitted with a syphonic valve. Other installation options such as direct feed from a non-potable supply tank or using a Zurn mains pressure are possible - refer to other literature.
- 4.2 All plumbing should be completed by a qualified tradesman.
- 4.3 The pipework should be completed as per Diagram 1. Care should be taken to ensure that the flow direction through the solenoid valve is as marked on the valve body. The valve supplied has an operating pressure range of 10 - 1000kPa, however we recommend the water pressure be in the 100 - 600kPa range for optimum performance. Fit a Wilkins Model NR3 pressure reducing valve if necessary. For long term reliability we recommend the installation of MacDonald FP51F Filterball valves as isolation valves and Wilkins 1250 water hammer arrestors.
- 4.4 Once the electrician has wired up the unit, it is necessary to regulate the water flow into the cistern tank. As previously described in Section 3.0 the solenoid valve will open twice during a cycle, each time for 90 seconds. It is imperative that you adjust the water flow so the cistern tank fills and dumps within the 90 second period - ideally around 70 - 80 seconds. This is done as follows;
- Plug the Water Guard into its 4 pin socket
  - Press and release the Re-set button on the back of the Water Guard. This will initiate a 2 second opening of the solenoid valve.
  - Pass your hand in front of the Water Guard to start a cycle. The LED on the front of the Water Guard will flutter slightly before starting a 1 sec ON, 1 sec OFF cycle. This will last for approximately 10 seconds. Then the LED will light continuously and the solenoid valve will open for 90 seconds.
  - Open the ball-o-fix valve until sufficient water is flowing to fill the tank in 70 - 80 seconds. If you are unsuccessful first time, repeat procedure.
  - IT IS VITAL to always start from an empty tank, so if flushing commences, say, after 60 seconds, pull the plug on the Water Guard and let the tank empty before trying again.
- 4.5 Many switch setting variations are available to suit your client's needs. The Water Guard is pre-set to flush on a 30 minute cycle, but this may not be suitable if traffic patterns are high. Alternative switch settings are shown in Section 6.0

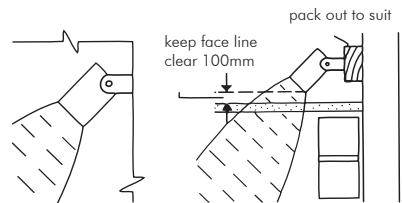


**5.0 ELECTRICAL INSTALLATION**

- 5.1 Electrical work should be carried out by a registered electrician.
- 5.2 The control unit should be positioned, if possible, to detect only people using the urinal. Detection field patterns are as per Diagram 2, but smaller lobes of detection can occur outside this main lobe.
- 5.3 Avoid pointing the control unit towards hallways or other areas where traffic patterns may encourage false triggering. Remember, Water Guard will detect through walls and ceilings up to a maximum distance of 4m.
- 5.4 Where there are multiple urinals and Water Guards, avoid pointing the control unit towards other urinals as water movement on these can also cause false triggering. Refer Section 6.2
- 5.5 The control unit can be mounted above a ceiling for out of sight installation, provided the thickness of the ceiling does not exceed 15mm and it is a non-conductive material such as Giboard, Hardiflex, plastic or glass. Materials such as sheet metal, foil or foil backed boards and wire reinforced glass should be avoided. See Diagram 3 for clearances.
- 5.6 The Clipsal 4 pin socket should be mounted adjacent to the controller and wired to mains as per Diagram 4. Removal of the plug may void warrantee offers.

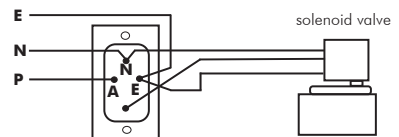


**Diagram 2**



**Diagram 3**

When the controller is plugged in, the red LED on the front of the controller should come on and flicker when movement is detected. Adjust the position of the controller to achieve suitable detection as per Section 5.2



Power  
 230V AC 50hz  
 Max Current 3A

**Diagram 4**

## 6.0 OPTIONS

Located on the back panel of the control unit is a small circular plate. Behind this is a series of 8 switches which give you the option of changing the flush cycle to suit your client's needs. There are 3 sections to these programme options;

### a) Single/Double flush cycle:

You have a choice of either only a flush at the end of the cycle or at both the beginning and the end.

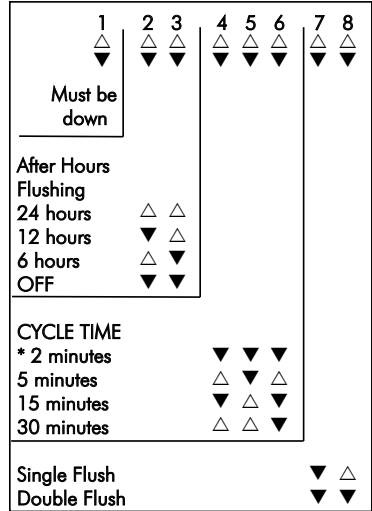
### b) Cycle time:

This option sets the length of the cycle. In the case of the single flush cycle, the solenoid will not open until the end of this period, but with the double flush cycle, the valve will open immediately detection is noted. and then again at the end of the cycle.

### c) After hours flushing:

This gives the option of regular after hours flushing to ensure the urinal trap stays wet and prevents odours. Ideal for schools, churches or similar that may have long dormant periods.

6.1 Where a large number of urinals or alternatively a single large urinal with a number of cistern tanks are installed, Water Guard can be installed with up to 5 solenoid valves being controlled from just one Water Guard controller.



### Recommended Settings

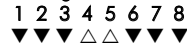
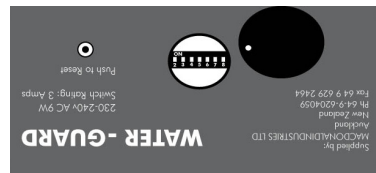


Diagram 5

\* 2 minute cycle time acts as a default should switches not be set in any of the settings shown above.

Not recommended for ultimate economy.



READ SWITCHES THIS WAY UP