

Z-6000XL-SL EXPOSED MOUNTED FLUSH VALVE FOR USE WITH SLUICE SINKS

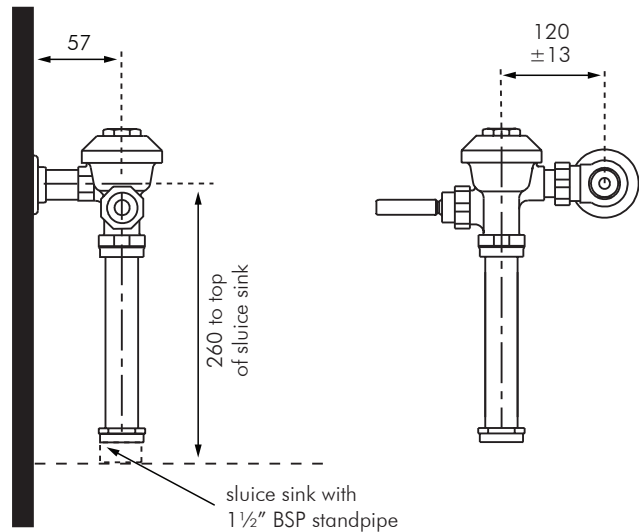

- Single Flush 6L (adjustable)
- Exposed Mounted
- Mains pressure, potable supply
- Chrome plated



DESCRIPTION

Zurn Model Z-6000XL-SL flush valve is a manually operated sluce sink flushing valve with toggle handle actuation with an approved vacuum breaker allowing direct connection to potable water supply without any additional backflow protection. The standard valve is pre-set to deliver a 6L flush and has achieved the distinction of Australian Standards Watermark approval and WELS 1 Star rating. Valve upgradable to 4.5L flushing should regulations permit.

Pipework design is critical to correct valve operation and must be completed by a suitably qualified person.

Flow rings supplied with the valve allow the installer to increase the flush volume to either 9 or 12 litres if required (WELS 0 Star rated).

In order to comply with approvals is not possible to remote mount this valve and extend any pipework.

SPECIFICATION

Suitable for connection to top entry sluce sink.

- Minimum Pressure:** 150kPa
- Maximum Pressure:** 500kPa
- Flow Rate:** 90L/min
- Inlet Connection:** 25mm BSP
- Flush Volume:** 6L

MODEL

Z-6000XL-SL - Standard valve with 25mm isolator.

