

# ZDF-6152XL

## WC MAINS PRESSURE DUAL FLUSH VALVES



### CONTENT OF STANDARD PACK

1. 1 x rough brass ZURN Aquaflush flush valve.
2. 1 x ZURN rough brass angled stop valve 1" BSP.
3. 1 x flush pipe set including.  
Vacuum breaker pipe, rubber duck bill, c/p horizontal flush pipe, elbow, wall escutcheon, rubber pan connector.
4. 700mm hydraulic hose set.  
NOTE: Push button set ordered separately. Available as shown below or with 340 x 340 access panel. Also available with push panel with or without concealed push plate access panel.

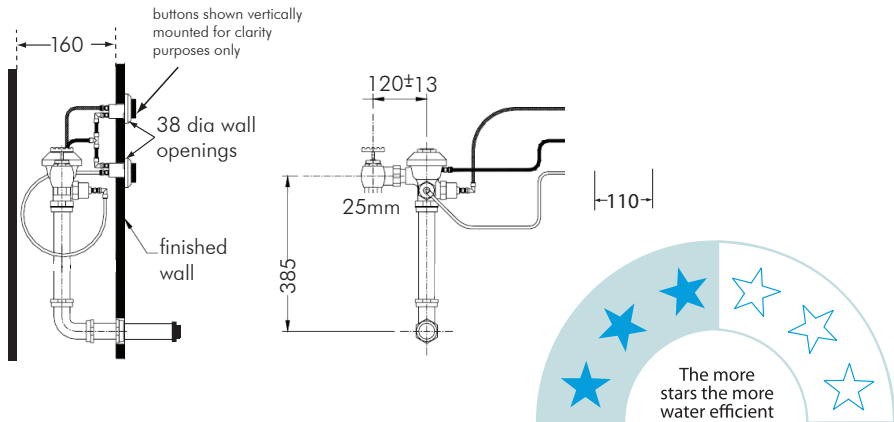

### VALVE DESCRIPTION

ZURN ZDF-6152XL is a commercial quality, diaphragm operated, hydraulically actuated, recess mounted brass WC flush valve designed to be connected to mains pressure (potable) water.

Valve is suitable for connection to back entry 6L WCs.

Pressing a remote push button will initiate either a 3L half flush or 6L full flush of the WC.

## APPROVALS

ZURN flush valves are approved under Watermark Schedule Licence No WMK00306 for Quality Assurance and backflow protection.



Under AS/NZS6400:2005 ZURN flush valves have WELS Registration. All dual flush valves achieve a 3 Star rating and single flush valves a 1 Star rating.

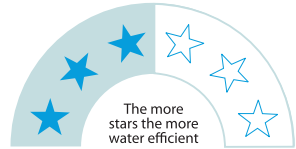

## PIPE SIZING AND DESIGN

ZURN flush valves rely on the capacity of the supply pipe to maintain the flow rate and pressure needed to evacuate the pan. A minimum of 25mm (nominal ID) supply is necessary to achieve this however much larger supply pipes may be required depending on;

- Supply pressure
- Length of pipe
- Number of valves installed
- Other fixtures using the supply pipe

**All pipework must be designed by a suitably qualified person** (services engineer or other) to achieve the necessary flow rate. Pressures given are dynamic pressure (under flow) not static head.

**Flow rate: 90L/min**

**Pressure: 150 - 500kPa (ideally 300 - 400kPa)**

**Connection: 25mm BSP**

Where it is not possible to achieve the pressure required, a roof supply tank should be fitted and a equivalent Non-Potable valve ordered. In those circumstances pipe sizing should be as per the Drainage & Plumbing Regs 1978.

As a rough guide the following chart can be used for mains pressure installations - this is intended as a guide only and pipe sizing should be checked by an engineer. The pipe size shown is the final horizontal pipe where the takeoff for the Zurn valve will be connected. Preceding pipe sizes may be larger depending on the size of the total contract. These sizes assume pressure in the 150 - 500 kPa range.

No of Valves	Pipe Size (mm)
1	25
2 - 3	32
4 - 12	38
13 - 24	50
25 - 50	65

NOTE: We recommend the use of Wilkins 1250 water hammer arrestors and 20g strainers where water quality is likely to cause problems to the Zurn valve.

## INSTALLATION

1. Fit isolator valve to 1" BSP threaded pipe. Refer to Page 1 for position of valve and nipple outlet position. Ensure minimum distance between water inlet and toilet is maintained to ensure effectiveness of backflow preventer.
2. Prior to fitting flush valve tail piece onto stop valve, ensure O ring is properly located in the seal groove at the end of the tail and that the snap ring is properly aligned. ALWAYS wet the O ring before fitting the stop valve.
3. Insert the flush valve tail piece into the stop valve and hand tighten the lock nut. Connect the vacuum breaker tube to the bottom of the valve ensuring the rubber duck bill is inserted in the top of the vacuum breaker tube.
4. It may be necessary to cut the vacuum breaker tube to suit the pan, but minimum heights must be observed. When cutting scored vacuum breaker tubes to fit, always leave at least 32mm of scoring to insure proper engagement with the compression coupling. To prevent back siphonage, the slots in the vacuum breaker tube MUST be a minimum of 200mm above the flood level of the WC. Fit the elbow and horizontal pipe, using the rubber pan connector to seal into the horn of the pan.
5. Hand tighten nuts only, adjust valve for plumb and then tighten all nuts.
6. Assembly of valve should be as per drawing on last page. Care should be taken when assembling hydraulic button assemblies. Hoses must connect as per diagram and 1/2 flush button must connect only to 1/2 flush hydraulic actuator.
7. Hydraulic tubing uses either compression or quick connect fittings to the valve body or push button assemblies. On fitting tubing, pull on tubing to ensure it has been securely assembled before turning water on.
8. Buttons should be mounted by drilling 2 x 38mm holes into wall 110mm apart. Disassemble the button bodies and screw fix into wall with the escutcheon plate fitted behind. Half flush button should be to the left - ensure tubes connecting buttons are assembled correctly. When button bodies and plate are fitted, screw cover and plastic button head to button bodies fixing with allen head screw beneath.
9. When all valves are installed and full water pressure is available it is necessary to flush out all lines to ensure no debris is left in the pipework.
  - a) close isolator
  - b) remove main brass cap from valve
  - c) remove plastic cover and diaphragm assembly
  - d) replace plastic cover and brass cap (less diaphragm assembly)
  - e) Open stop valve and flush out debris
  - f) Shut stop valve and reassemble valve
10. The ZURN Aquaflush valve is designed to flush 6L of water over a wide range of pressures however some adjustment of the stop valve may be necessary to ensure correct operation and to minimise pan splash, particularly at higher pressures.
11. Compliance with Watermark approvals means this valve must not be modified in any way. Warrantee may be void if valve is installed in any other way than recommended in this document.

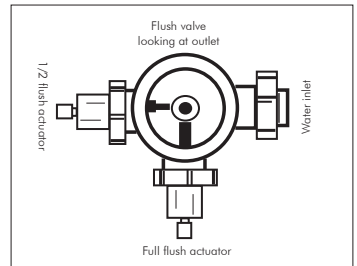

## ASSEMBLY DIAGRAM

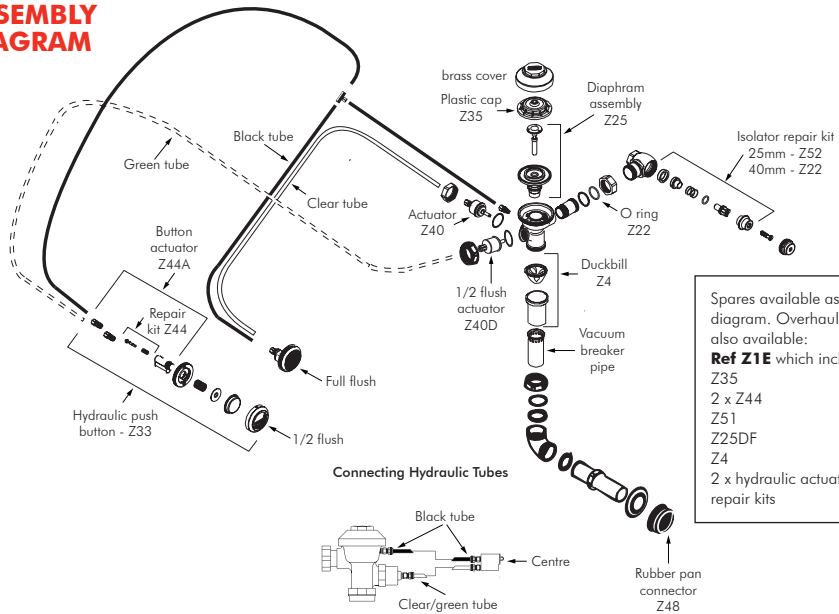

## MAINTENANCE

Problem	Cause	Remedy
Poor/inadequate flush	Incorrect pipe sizing or inadequate pressure	Increase pipe supply, boost pressure
Short flush	Faulty diaphragm - bypass hole oversize Excessive pressure Stop valve not correctly adjusted	Replace diaphragm assembly Fit Wilkins pressure reducing valve Turn down stop valve to extend flush time
Valve won't shut off	Insufficient line pressure to repressurize valve By pass hole blocked/debris under diaphragm Trip mechanism not sealing	Increase pipe supply, boost pressure Clear debris Replace diaphragm assembly
Leaking from vacuum breaker slots	Back pressure from WC Duckbill faulty	Check pan connector to pan is clear Replace duckbill
Continuous water trickle	Hydraulic tubing is installed incorrectly Hydraulic push button has been fouled	Refer to instructions Remove button valve and clean
Valve will not flush	Water supply cut off Hydraulic Actuator jammed	Turn water on Remove, disassemble and clean. Check cup seal on actuator pin is not distorted



**MACDONALD  
INDUSTRIES LIMITED**

### Auckland (Head Office)

20 Carr Rd, Three Kings  
Auckland 1041

P: 09 624 1115

F: 09 624 1110

E: sales@macdonaldindustries.co.nz

### Wellington

P: 04 569 8033

F: 04 569 8066

### Christchurch

P: 03 348 2356

F: 03 348 2376

www.macdonaldindustries.co.nz

## CONNECTING HYDRAULIC TUBES TO ZURN FLUSH VALVES

All Zurn hydraulically activated flush valves require the plumber to assemble the hydraulic tubing as shown on page 4 of the enclosed Installation Instructions.

Care should be taken to ensure the connections are made good and that a pull test is completed after assembly to ensure a secure connection has been made.

**In particular the black hose connections are important as this hose is constantly charged with mains pressure water.**

The black hose is connected to the upper connection on the valve body using a brass nut and plastic olive (Ref. 1).

If shortening the hose it must be cut square without burrs before assembly.

Slide over fitting on valve body (Ref. 2) ensuring tube is pushed all the way in.

Tighten nut using a spanner to ensure complete compression of olive. If correctly assembled the olive will distort as per picture (Ref. 3).

Pull on hose hard to check connection and if necessary unscrew nut to verify compression of olive. If it has been correctly assembled the tube and olive will lock together and be difficult to separate.

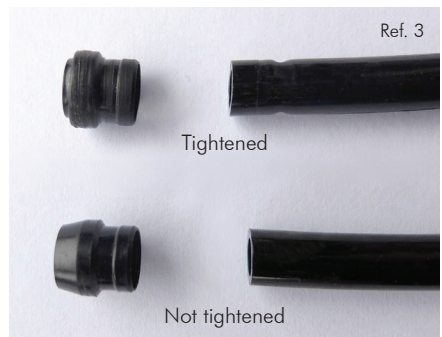

**MACDONALD  
INDUSTRIES LIMITED**

**Auckland (Head Office)**

20 Carr Rd, Three Kings  
Auckland 1042  
P: 09 624 1115  
F: 09 624 1110

E: [sales@macdonaldindustries.co.nz](mailto:sales@macdonaldindustries.co.nz)

**Wellington**

P: 04 569 8033  
F: 04 569 8066

**Christchurch**

P: 03 348 2356  
F: 03 348 2376

[www.macdonaldindustries.co.nz](http://www.macdonaldindustries.co.nz)