

DE492006
TEMPOMATIC MIX 3
ELECTRONIC BASIN MIXER

DELABIE

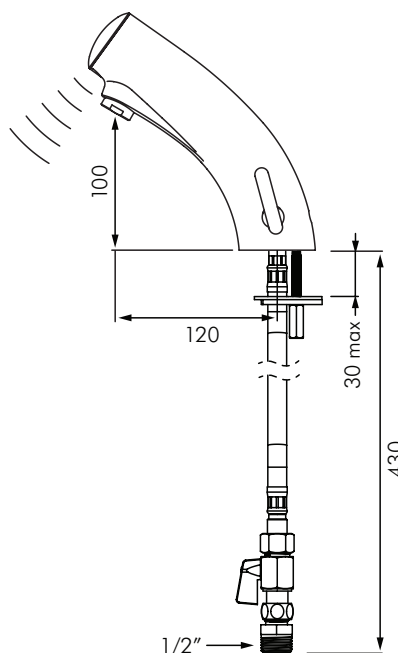

DESCRIPTION

DELABIE DE492006 is a deck mounted battery powered electronic basin mixer with a reduced stagnation solenoid valve and electronic unit with 6V Lithium battery integrated into the body of the tap. Anti-bacterial duty flush operates for ~60 seconds every 24 hours after last use. Side temperature control with adjustable maximum temperature limiter. Flow rate is pre-set at 3L/min at 300kPa, can be adjusted from 1.5 to 6L/min. Operating pressure is 100-500kPa, 300kPa is recommended. Chrome-plated solid brass body with hygienic scale-resistant flow straightener and reinforced fixing.

Supplied with PEX flexible connectors, filters, non-return valves and M1/2" stopcocks.

INSTALLATION

- Deck mounted through Ø34mm hole.
- Reinforced fixation using 2x stainless steel fixing screws and support ring.
- 400mm PEX flexibles connect to 1/2" water supply.
- Equal Hot & Cold supply pressure (max 15% variation).
- Maximum Hot water temperature 55°C.
- Flow rate pre-set at 3L/min at 300kPa, can be adjusted from 1.5 to 6L/min by using a 2.5mm Allen key directly on the flow straightener.
- Ensure basin waste position does not conflict with position of the sensor.
- Low battery life will cause LED to blink for 15 days.
- Battery is replaced from within the electronic unit, access via removal of 2x 2.5mm Allen ket screws.

MODELS

- DE492006** - Standard model 3L/min - 6 star WELS rating.
- DE492006LH** - Same as DE492006 but with long handle side temperature control.